

V200-18-E3B Snap-in I/O Module

The V200-18-E3B plugs directly into the back of compatible Unitronics OPLCs, creating a self-contained PLC unit with a local I/O configuration.

Features



- 18 isolated digital inputs, includes 2 H.S.C inputs, type pnp/npn (source/sink)
- 15 isolated relay outputs
- 2 isolated pnp/npn (source/sink) transistor outputs, includes 2 H.S. outputs
- 4 isolated analog/PT100/TC inputs
- 4 isolated analog outputs

- Before using this product, it is the responsibility of the user to read and understand this document and any accompanying documentation.
- All examples and diagrams shown herein are intended to aid understanding, and do not guarantee operation. Unitronics accepts no responsibility for actual use of this product based on these examples.
- Please dispose of this product in accordance with local and national standards and regulations.
- Only qualified service personnel should open this device or carry out repairs.

User safety and equipment protection guidelines

This document is intended to aid trained and competent personnel in the installation of this equipment as defined by the European directives for machinery, low voltage, and EMC. Only a technician or engineer trained in the local and national electrical standards should perform tasks associated with the device's electrical wiring.

Symbols are used to highlight information relating to the user's personal safety and equipment protection throughout this document. When these symbols appear, the associated information must be read carefully and understood fully.

Symbol	Meaning	Description
	Danger	The identified danger causes physical and property damage.
	Warning	The identified danger can cause physical and property damage.
<i>Caution</i>	Caution	Use caution.



- Failure to comply with appropriate safety guidelines can result in severe personal injury or property damage. Always exercise proper caution when working with electrical equipment.



- Check the user program before running it.
- Do not attempt to use this device with parameters that exceed permissible levels.
- Install an external circuit breaker and take appropriate safety measures against short-circuiting in external wiring.
- To avoid damaging the system, do not connect / disconnect the device when the power is on.

Caution

- Ascertain that terminal blocks are properly secured in place.

Environmental Considerations



- Do not install in areas with: excessive or conductive dust, corrosive or flammable gas, moisture or rain, excessive heat, regular impact shocks or excessive vibration.



- Provide proper ventilation by leaving at least 10mm of space between the top and bottom edges of the device and the enclosure walls.
- Do not place in water or let water leak onto the unit.
- Do not allow debris to fall inside the unit during installation.

Wiring



- Do not touch live wires.



- Unused pins should not be connected. Ignoring this directive may damage the device.
- Do not connect the 'Neutral' or 'Line' signal of the 110/220VAC to the device's 0V pin.
- Double-check all wiring before turning on the power supply.

Wiring Procedures

Use crimp terminals for wiring; use 26-12 AWG wire (0.13 mm²–3.31 mm²) for all wiring purposes.

1. Strip the wire to a length of 7±0.5mm (0.250–0.300 inches).
 2. Unscrew the terminal to its widest position before inserting a wire.
 3. Insert the wire completely into the terminal to ensure that a proper connection can be made.
 4. Tighten enough to keep the wire from pulling free.
- To avoid damaging the wire, do not exceed a maximum torque of 0.5 N·m (5 kgf·m).
 - Do not use tin, solder, or any other substance on stripped wire that might cause the wire strand to break.
 - Install at maximum distance from high-voltage cables and power equipment.

I/O Wiring—General

- Input or output cables should not be run through the same multi-core cable or share the same wire.
- Allow for voltage drop and noise interference with input lines used over an extended distance. Use wire that is properly sized for the load.

Digital Inputs

Each group of 9 inputs has a common signal. Each group can be used as either pnp (source) or npn (sink), when appropriately wired as shown in the following figures.

Inputs I0 and I2 can be used as normal digital inputs, as high-speed counters, or as part of a shaft encoder. Inputs I1 and I3 can be used as normal digital inputs, as high-speed counter resets, or as part of a shaft encoder.

npn (sink) digital input wiring

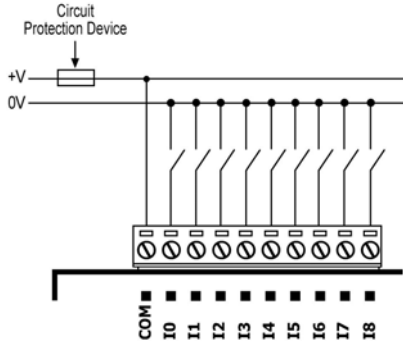

pnp (source) digital input wiring

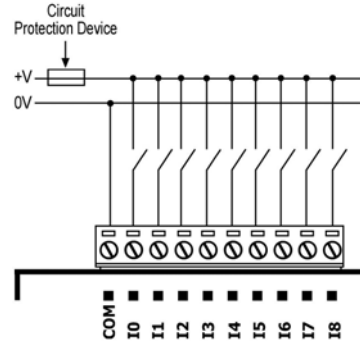

npn (sink) high-speed counter

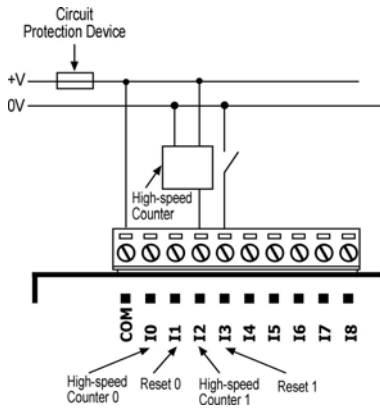

pnp (source) high-speed counter

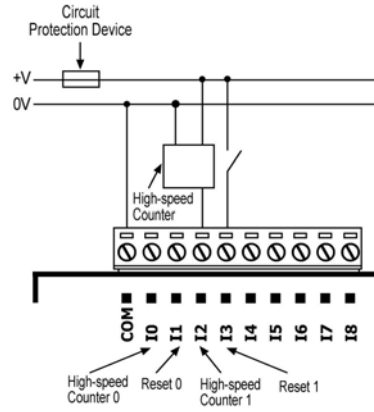

Inputs I0, I1, and I2, I3 can be used as shaft encoders as shown below.

npn (sink) shaft encoder wiring

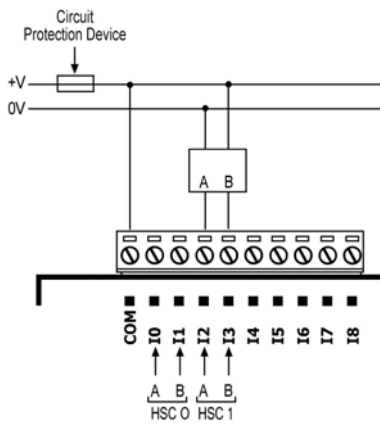

pnp (source) shaft encoder wiring

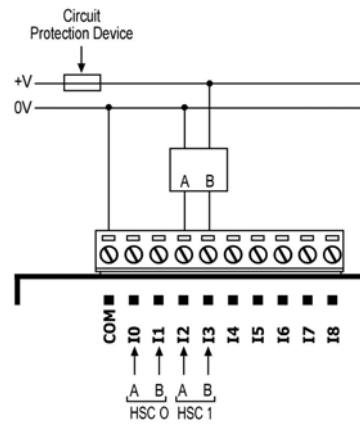

Digital Outputs

Wiring Power Supplies

Use a 24VDC power supply for both relay and transistor outputs.

1. Connect the "positive" lead to the "V1" terminal, and the "negative" lead to the "0V" terminal.
- In the event of voltage fluctuations or non-conformity to voltage power supply specifications, connect the device to a regulated power supply

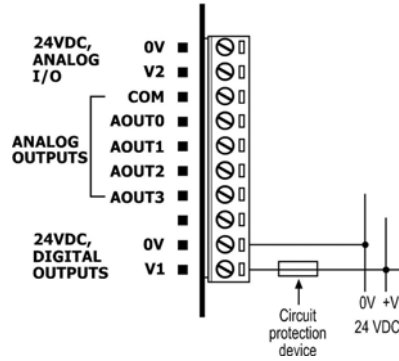

Relay Outputs

- Each output can be wired separately to either AC or DC as show below.
- The 0V signal of the relay outputs is isolated from the controller's 0V signal.

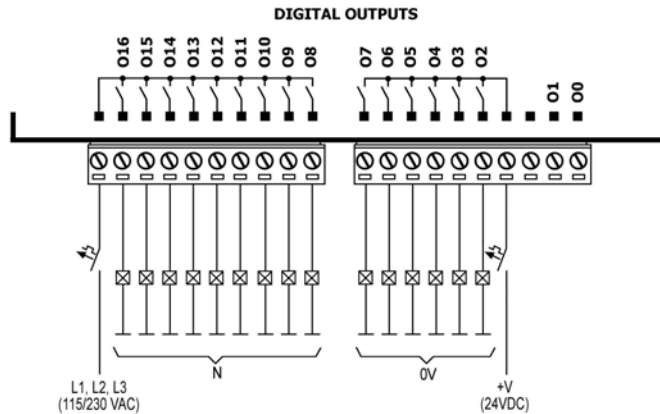

Increasing Contact Life Span

To increase the life span of the relay output contacts and protect the device from potential damage by reverse EMF, connect:

- a clamping diode in parallel with each inductive DC load,
- an RC snubber circuit in parallel with each inductive AC load.

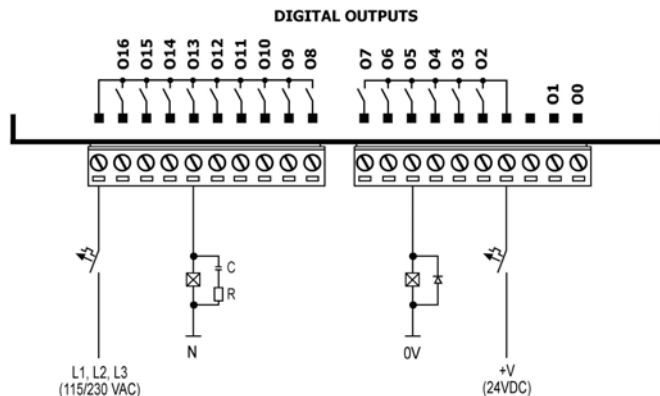

Transistor Outputs

- Each output can function as either npn or pnp, in accordance with jumper settings and wiring. Open the device and set the jumpers according to the instructions beginning on page 8.
- The 0V signal of the transistor outputs is isolated from the controller's 0V signal.

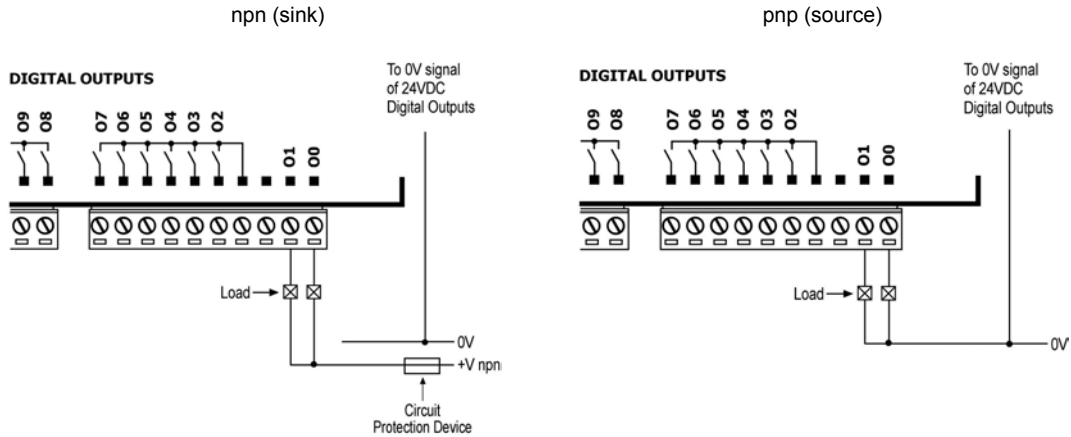

Analog I/O Power Supplies

Use a 24VDC power supply for all analog input and output modes.

1. Connect the "positive" cable to the "V2" terminal, and the "negative" to the "0V" terminal.
- In the event of voltage fluctuations or non-conformity to voltage power supply specifications, connect the device to a regulated power supply.
 - Since the analog I/O power supply is isolated, the controller's 24VDC power supply may also be used to power the analog I/Os.

The 24VDC power supply must be turned on and off simultaneously with the controller's power supply.

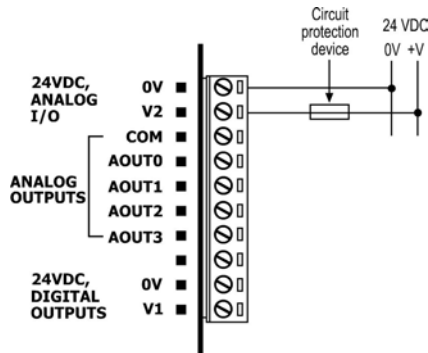

Analog / PT100 / TC Inputs

- Each input may be set as either analog, RTD, or thermocouple. To set an input:
 - Use the appropriate wiring as shown below.
 - Open the device and set the jumpers according to the instructions beginning on page 8.
- Shields should be connected at the signal source.
- In order to function correctly, the analog power supplies must be wired as shown on page 5.
- To ensure proper performance, a warm-up period of a half an hour is recommended.

Analog Inputs

- Inputs may be wired to work with either current or voltage.
- When set to current/voltage, all inputs share a common ACM signal.

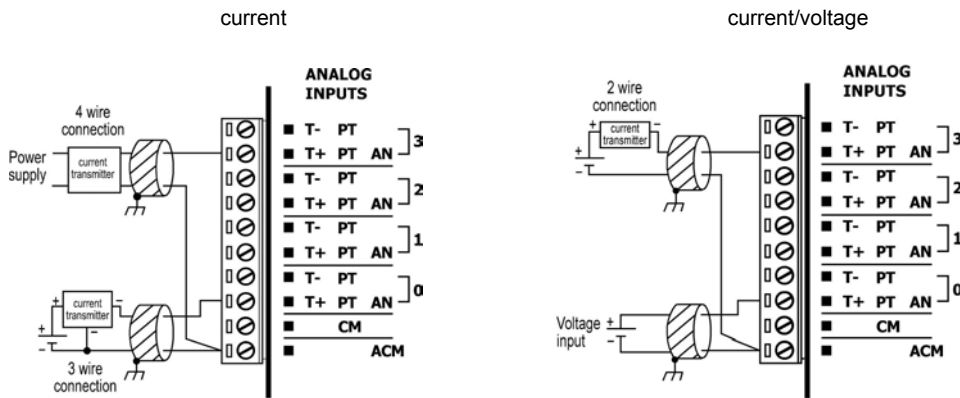

RTD Inputs

1. Wire one lead of each thermocouple input to the common signal (CM) as shown below.
 2. Wire the CM to the ACM signal as shown below, using a single wire, not exceeding 2 cm in length.
- 4 wire PT100 can be used by leaving one of the sensor leads unconnected.

PT100

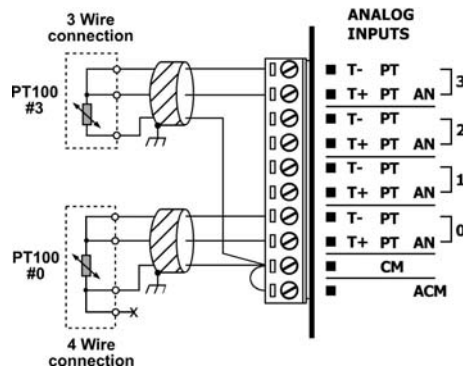

Thermocouple Inputs

- Supported thermocouple types include B, E, J, K, N, R, S, and T, in accordance with software and jumper settings. See table Thermocouple Input Ranges, on page 15.

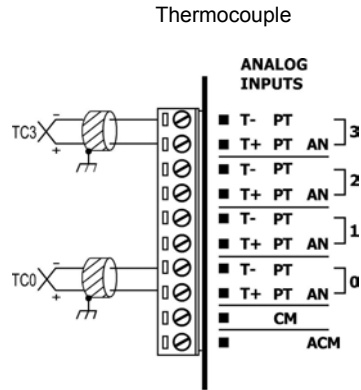

Analog Outputs

- Shields should be earthed, connected to the earth of the cabinet.
- An output can be wired to either current or voltage.
 - Use the appropriate wiring as shown below.
 - Open the device and set the jumpers according to the instructions beginning on page 8.
- To ensure proper performance, a warm-up period of a half an hour is recommended.

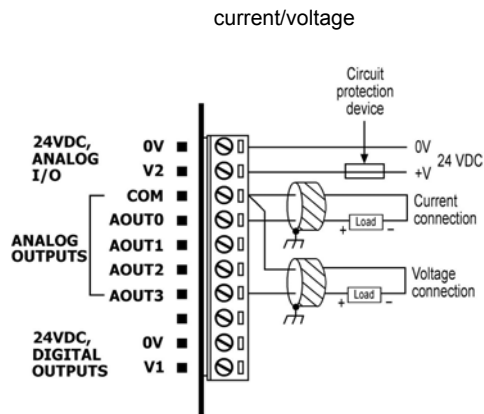

Changing Jumper Settings

To access the jumpers, you must remove the snap-in I/O module from the controller, and then remove the module's PCB board. Before you begin, turn off the power supply, disconnect and dismount the controller.



- Before performing these actions, touch a grounded object to discharge any electrostatic charge.
- Avoid touching the PCB board directly by holding the PCB board by its connectors.

Accessing the Jumpers

First, remove the snap-in module.

1. Locate the 4 buttons on the sides of the module, two on either side. Press the 2 buttons on either side of the module as shown, and hold them down to open the locking mechanism.
2. Gently rock the module from side to side, easing the module from the controller.

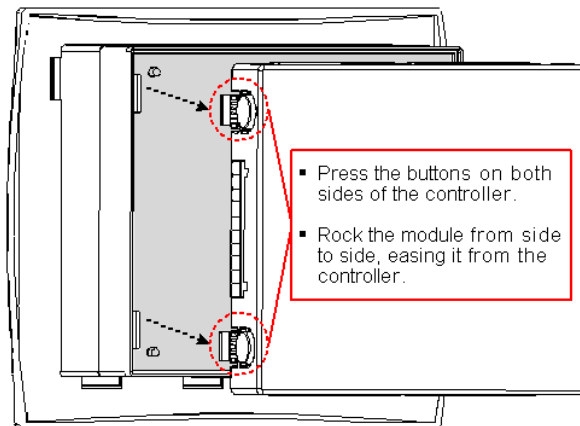

3. Using a Philips screwdriver, remove the center screw, shown in the figure below, from the module's upper PCB board. **Do not remove any other screws.**
4. Holding the PCB board by its edges, gently lift it out of the module.

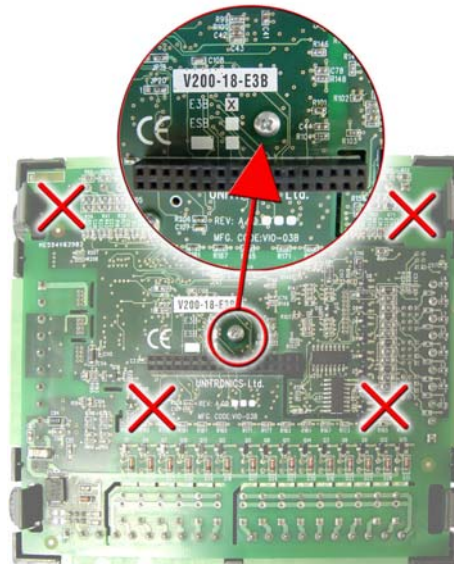

Select the desired function by changing the jumper settings according to the figure and tables shown below.

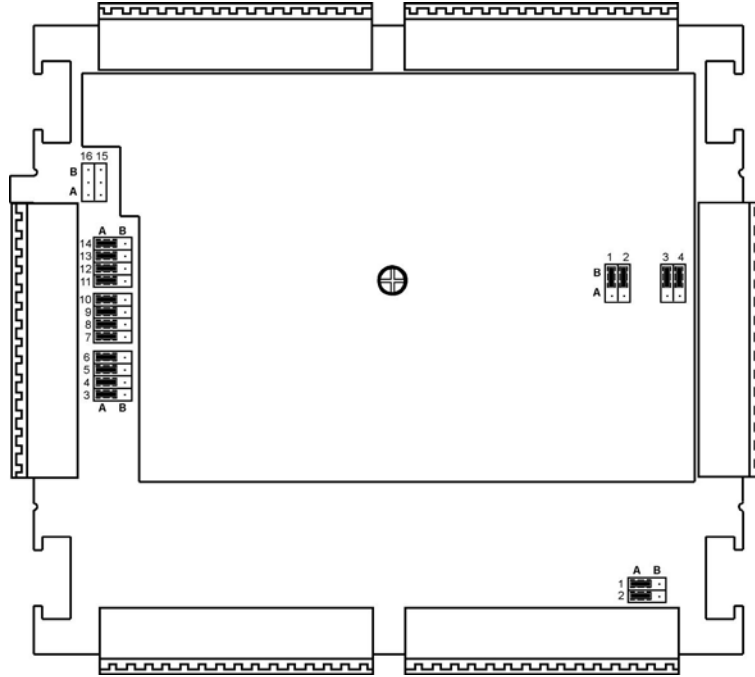

Analog Input Jumpers

		Jumper #	Voltage*	Current	T/C	PT100
Bottom PCB board	Analog input 3	14	A	B	B	A
		13	A	B	B	A
		12	A	A	B	B
	Analog input 2	11	A	B	B	A
		10	A	B	B	A
		9	A	A	B	B
	Analog input 1	8	A	B	B	A
		7	A	B	B	A
		6	A	A	B	B
	Analog input 0	5	A	B	B	A
		4	A	B	B	A
		3	A	A	B	B

Digital Output Jumpers

Note that Jumpers #15 & 16 are not used

	Jumper #	PNP*	NPN
Digital Output 0	1	A	B
Digital Output 1	2	A	B

Analog Output Jumpers

		Jumper #	Current	Voltage*
Top PCB board	Analog Output 0	1	A	B
	Analog Output 1	2	A	B
	Analog Output 2	3	A	B
	Analog Output 3	4	A	B

* Default factory setting

Reassembling the controller

1. Return the PCB board to the module and secure the center screw.
2. Next, reinstall the module. Line the circular guidelines on the controller up with the guidelines on the Snap-in I/O Module as shown below.
3. Apply even pressure on all 4 corners until you hear a distinct 'click'. The module is now installed. Check that all sides and corners are correctly aligned.

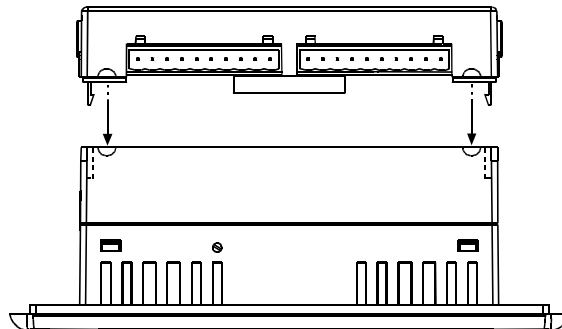

V200-18-E3B Technical Specifications

Digital Inputs

Number of inputs	18 (in two groups)
Input type	pnp (source) or npn (sink)
Galvanic isolation	
Digital inputs to bus	Yes
Digital inputs to digital inputs in same group	No
Group to group, digital inputs	Yes
Nominal input voltage	24VDC
Input voltage	
pnp (source)	0-5VDC for Logic '0' 17-28.8VDC for Logic '1'
npn (sink)	17-28.8VDC for Logic '0' 0-5VDC for Logic '1'
Input current	6mA@24VDC for inputs #4 to #17 8.8mA@24VDC for inputs #0 to #3
Response time	10mSec typical
High speed inputs	Specifications below apply when these inputs are wired for use as a high-speed counter input/shaft encoder. See Notes 1 and 2.
Resolution	32-bit
Frequency	10kHz maximum
Minimum pulse width	40µs

Notes:

- Inputs #0 and #2 can each function as either high-speed counter or as part of a shaft encoder. In each case, high-speed input specifications apply. When used as a normal digital input, normal input specifications apply.
- Inputs #1 and #3 can each function as either counter reset, or as a normal digital input; in either case, its specifications are those of a normal digital input. These inputs may also be used as part of a shaft encoder. In this case, high-speed input specifications apply.

Digital Outputs

Digital Output's Power Supply

Nominal operating voltage	24VDC
Operating voltage	20.4 to 28.8VDC
Quiescent current	20mA@24VDC.
Max. current consumption	85mA@24VDC. See Note 3.
Galvanic isolation	
Digital power supply to bus	Yes
Digital power supply to relay outputs	Yes
Digital power supply to transistor outputs	No

Notes:

- Maximum current consumption does not provide for PNP output requirements. The additional current requirement of PNP outputs must be added.

Relay Outputs

Number of outputs	15 (in two groups). See Note 4.
Output type	SPST-NO relay; 230VAC / 24VDC
Type of relay	Takamisawa (Fujitsu) NY-24W-K or NAIS (Matsushita) PA1a-24V
Outputs' power supply	See Digital Output's Power Supply above
Galvanic isolation	
Relay outputs to bus	Yes
Group to group, relay outputs	Yes
Relay to transistor outputs	Yes
Output current	<u>Resistive Load</u> 3A maximum per output 8A maximum total for common. See Note 4. <u>Inductive Load</u> 1A maximum per output 4A maximum total for common. See Note 4.
Maximum frequency	0.5Hz (at maximum rated load)
Contact protection	External precautions required (see Increasing Contact Life Span, p.4)

Notes:

- Outputs #2,3,4,5,6 and 7 share a common signal. Outputs #8,9,10,11,12,13,14,15 and 16 share a common signal

Transistor Outputs

Number of outputs	2, high-speed. Each can be individually set as pnp (source) or npn (sink) via wiring and jumper settings. See Note 5.
Output type	pnp: P-MOSFET (open drain) nnp: N-MOSFET (open drain)
Galvanic isolation	
Transistor outputs to bus	Yes
Transistor outputs to transistor outputs	No
Transistor outputs to relay outputs	Yes
Output current	pnp: 0.5A maximum per output nnp: 50mA maximum per output
Maximum frequency	<u>Resistive load</u> pnp: 2kHz nnp: 20kHz <u>Inductive load</u> 0.5Hz
ON voltage drop	pnp: 0.5VDC maximum nnp: 0.4VDC maximum
Short circuit protection	Yes (pnp only)
pnp (source) power supply	See Digital Output's Power Supply above
nnp (sink) power supply	
operating voltage	3.5V to 28.8VDC, unrelated to the voltage of either the I/O module or the controller

Notes:

- Both transistor outputs may be used as high-speed outputs.

Analog I/O's Power Supply

Nominal operating voltage	24VDC
Operating voltage	20.4 to 28.8VDC
Quiescent current	70mA@24VDC
Max. current consumption	130mA@24VDC
Galvanic isolation	
Analog power supply to bus	Yes
Analog power supply to analog inputs	Yes
Analog power supply to analog outputs	Yes

Analog/ PT100/ TC Inputs

Number of inputs	4
Type of input	Set via appropriate wiring and jumper settings.

Analog Inputs Power Supply

Galvanic isolation	
Analog/PT/TC inputs to bus	Yes
Analog/PT/TC inputs to analog outputs	Yes
Analog /PT/TC inputs to Analog /PT/TC inputs	No

Analog inputs

Input range	0-10V, 0-20mA , 4-20mA
Power supply	See Analog I/O's Power Supply above
Conversion method	Successive approximation
Resolution at 0-10V, 0-20mA	12-bit (4096 units)
Resolution at 4-20mA	819 to 4095 (3277 units)
Conversion time	Synchronized to cycle time
Input impedance	>1M Ω —voltage 121.5 Ω —current
Absolute maximum rating	\pm 20V—voltage \pm 40mA—current
Full-scale error	\pm 0.1%
Linearity error	\pm 0.025%
Status indication	Yes. See Note 6

Notes:

6. The analog value can indicate faults as shown below:

<u>Value</u>	<u>Possible Cause</u>
4096	Input value deviates slightly above the input range
32767	-Input value deviates greatly above or below the input range -Power supply disconnected

PT100 inputs

Input range	-200 to 600°C/-328 to 1100°F. 1 to 320Ω. See Note 7.
Conversion method	Voltage to frequency
Resolution	0.1°C/0.1°F
Conversion time	200mS minimum per channel, depending on software filter type
Input impedance	>10MΩ
Auxillary current for PT100	150μA typical
Full-scale error	±0.4%
Linearity error	±0.04%
Status indication	Yes. See Note 8.

Notes:

- The device can also measure resistance with the range of 1-320 Ω at a resolution of 0.1 Ω.
- The analog value can indicate faults as shown below:

<u>Value</u>	<u>Possible Cause</u>
32767	- Sensor is not connected to input. - Value exceeds permissible range - Power supply disconnected
-32767	Sensor is short-circuited

Thermocouple inputs

Input range	As shown in the table on page 15. See Note 9.
Conversion method	Voltage to frequency
Resolution	0.1°C/0.1°F maximum
Conversion time	100mS minimum per channel, depending on software filter type
Input impedance	>10MΩ
Cold junction compensation	Local, automatic
Cold junction compensation error	±1.5°C / ±2.7°F maximum
Absolute maximum rating	±0.6VDC
Full-scale error	±0.4%
Linearity error	±0.04%
Warm-up time	½ hour typically, ±1°C/±1.8°F repeatability
Status indication	Yes. See Note 10.

Notes:

- The device can also measure voltage within the range of -5 to 56mV, at a resolution of 0.01mV. The device can also measure raw value frequency at a resolution of 14-bits(16384)
- The analog value can indicate faults as shown below:

<u>Value</u>	<u>Possible Cause</u>
32767	- Sensor is not connected to input. - Value exceeds permissible range - Power supply disconnected

Table 1: Thermocouple input ranges

Type	Temperature range	Wire Color	
		ANSI (USA)	BS 1843 (UK)
mV	-5 to 56mV	-	-
B	200 to 1820°C (300 to 3276°F)	+Grey -Red	+None -Blue
E	-200 to 750°C (-328 to 1382°F)	+Violet -Red	+Brown -Blue
J	-200 to 760°C (-328 to 1400°F)	+White -Red	+Yellow -Blue
K	-200 to 1250°C (-328 to 2282°F)	+Yellow -Red	+Brown -Blue
N	-200 to 1300°C (-328 to 2372°F)	+Orange -Red	+Orange -Blue
R	0 to 1768°C (32 to 3214°F)	+Black -Red	+White -Blue
S	0 to 1768°C (32 to 3214°F)	+Black -Red	+White -Blue
T	-200 to 400°C (-328 to 752°F)	+Blue -Red	+White -Blue

Analog Outputs

Number of outputs	4 (single-ended)
Output range	0-10V, 4-20mA. See Note 11.
Resolution	12-bit (4096 units)
Conversion time	Synchronized to scan time.
Load impedance	1kΩ minimum—voltage 500Ω maximum—current

Galvanic isolation

Analog outputs to bus	Yes
Analog outputs to Analog/PT/TC inputs	Yes
Analog outputs to analog outputs	No

Linearity error	±0.1%
Operational error limits	±0.2%

Notes:

11. Note that the range of each I/O is defined by wiring, jumper settings, and within the controller's software.

Environmental

	IP20 / NEMA1
Operating temperature	0° to 45°C (32° to 113°F)
Storage temperature	-20° to 60° C (-4° to 140°F)
Relative Humidity (RH)	5% to 90% (non-condensing)
Dimensions (WxHxD)	138x23x123mm (5.43x0.9x4.84")
Weight	222g (7.83 oz)

About Unitronics

Unitronics Industrial Automation Systems has been producing PLCs, automation software and accessory devices since 1989.

Unitronics' OPLC controllers combine full-function PLCs and HMI operating panels into single, compact units. These HMI + PLC devices are programmed in a single, user-friendly environment. Our clients save I/O points, wiring, space, and programming time; elements that translate directly into cost-efficiency.

Unitronics supports a global network of distributors and sales representatives, as well as a U.S. subsidiary.

For more information regarding Unitronics products, contact your distributor or Unitronics headquarters via email: export@unitronics.com.



Under no circumstances will Unitronics be liable or responsible for any consequential damage that may arise as a result of installation or use of this equipment, and is not responsible for problems resulting from improper or irresponsible use of this device.

No part of this document may be used for any purpose other than for the purposes specifically indicated herein nor may it be reproduced or transmitted in any form or by any means, electronic or mechanical, including photocopying and/or recording, for any purpose without written permission from Unitronics.

The information appearing in this document is for general purposes only. Unitronics makes no warranty of any kind with regard to the information appearing in this document, including, but not limited to, implied warranties of merchantability and/or fitness for a particular use or purpose. Unitronics assumes no responsibility for the results, direct and/or indirect, of any misuse of the information appearing in this document nor for any use of the Unitronics products referred to herein in any manner deviating from the recommendations made in this document. Unitronics assumes no responsibility for the use of any parts, components, or other ancillary appliances including circuitry other than as recommended hereunder or other than that embodied in the Unitronics product.

Unitronics retains all rights to its proprietary assets including, but not limited to its software products which are copyrighted and shall remain the property of Unitronics. Copyright protection claimed includes all Forms and matters of copyrightable materials and information legally allowed including but not limited to material generated from the software programs which are displayed on the screen of the Unitronics products such as styles, templates, icons, screen displays, looks, etc. Duplication and/or any unauthorized use thereof are strictly prohibited without prior written permission from Unitronics.

All brand or product names are used for identification purpose only and may be trademarks or registered trademarks of their respective holders.

Unitronics reserves the right to revise this publication from time to time and to amend its contents and related hardware and software at any time. Technical updates (if any) may be included in subsequent editions (if any).

Unitronics product sold hereunder can be used with certain products of other manufacturers at the user's sole responsibility.