

The V200-18-E1 plugs directly into the back of compatible Unitronics OPLCs, creating a self-contained PLC unit with a local I/O configuration.

The module offers:

- 3 analog inputs
- 16 digital inputs including 2 high-speed inputs, type pnp/npn (source/sink)
- 10 relay outputs
- 4 pnp/npn (source/sink) transistor outputs, including 2 high-speed outputs

User safety and equipment protection guidelines

This document is intended to aid trained and competent personnel in the installation of this equipment as defined by the European directives for machinery, low voltage and EMC. Only a technician or engineer trained in the local and national electrical standards should perform tasks associated with the electrical wiring of this device.

- Under no circumstances will Unitronics be liable or responsible for any consequential damage that may arise as a result of installation or use of this equipment, and is not responsible for problems resulting from improper or irresponsible use of this device.
- All examples and diagrams shown in the manual are intended to aid understanding. They do not guarantee operation.
- Unitronics accepts no responsibility for actual use of this product based on these examples.
- Only qualified service personnel should open this device or carry out repairs.
- Please dispose of this product in accordance with local and national standards and regulations.



- Failure to comply with appropriate safety guidelines can result in severe personal injury or property damage. Always exercise proper caution when working with electrical equipment.



- Check the user program before running it.
- Do not attempt to use this device with voltage exceeding permissible levels.
- Install an external circuit breaker and take all appropriate safety measures against short-circuiting in external wiring.

Environmental Considerations

- Do not install in areas with: excessive or conductive dust, corrosive or flammable gas, moisture or rain, excessive heat, regular impact shocks or excessive vibration.
- Leave a minimum of 10mm space for ventilation between the top and bottom edges of the device and the enclosure walls.
- Do not place in water or let water leak onto the unit.
- Do not allow debris to fall inside the unit during installation.

Wiring

Wiring Safety Guidelines



- Do not touch live wires.
- Do not connect the 'Neutral' or 'Line' signal of the 110/220VAC to the device's 0V pin.
- Double-check all wiring before turning on the power supply.

Wiring Considerations

- Do not use tin, solder or any other substance on stripped wire that might cause the wire strand to break.
- Install at maximum distance from high-voltage cables and power equipment.

Wiring Procedures

Use crimp terminals for wiring; use 26-12 AWG wire (0.13 mm²–3.31 mm²) for all wiring purposes.

- 1) Strip the wire to a length of 7±0.5mm (0.250–0.300 inches).
- 2) Unscrew the terminal to its widest position before inserting a wire.
- 3) Insert the wire completely into the terminal to ensure that a proper connection can be made.
- 4) Tighten enough to keep the wire from pulling free.

To avoid damaging the wire, do not exceed a maximum torque of 0.5 N·m (5 kgf·m).

I/O Wiring

- Input or output cables should not be run through the same multi-core cable or share the same wire.
- Allow for voltage drop and noise interference with input lines used over an extended distance. Use wire that is properly sized for the load.

Digital Inputs

Each group of 8 inputs has a jumper, shown on the back of the module in the figure below. Each group can be used as npn (source) or npn (sink). This requires both that the jumper be correctly located, and that the inputs be appropriately wired as shown in the following figures.

Inputs 10 and 12 can be used as normal digital inputs, as high-speed counters, or as part of a shaft encoder.

Inputs 11 and 13 can be used as normal digital inputs or as high-speed counter resets, or as part of a shaft encoder.

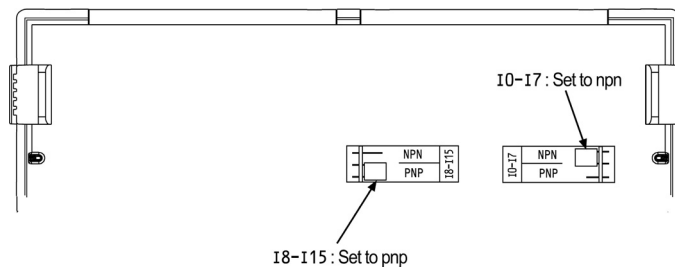

nnp (sink) digital input wiring

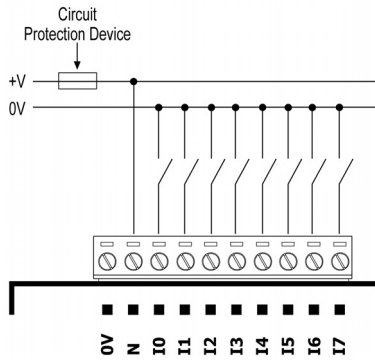

pnnp (source) digital input wiring

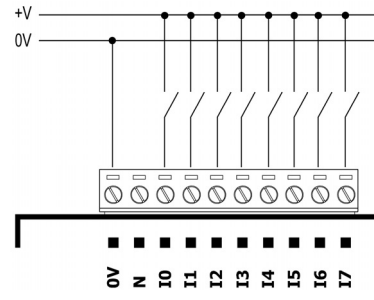

nnp (sink) high-speed counter

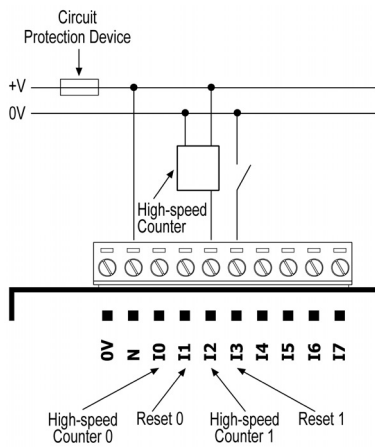

pnnp (source) high-speed counter

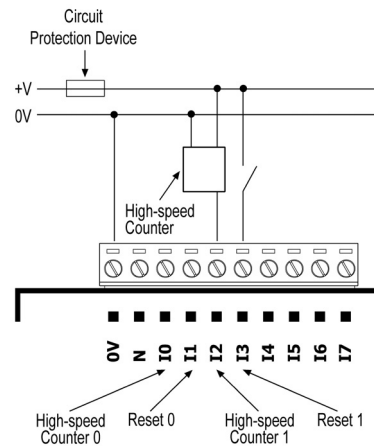

Inputs I0, I1, and I2, I3 can be used as shaft encoders.

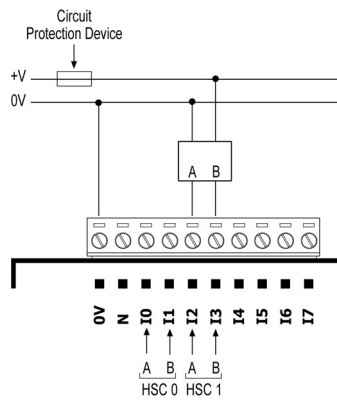

Digital Outputs

Wiring Power Supplies

- 1 Connect the "positive" lead to the "V1" terminal for the relay outputs, to the V2 terminal for the transistor outputs.
 - 2 In both cases, connect the "negative" lead to the "0V" terminal of each output group.
- A non-isolated power supply can be used provided that a 0V signal is connected to the chassis.
 - In the event of voltage fluctuations or non-conformity to voltage power supply specifications, connect the device to a regulated power supply.

Relay Outputs

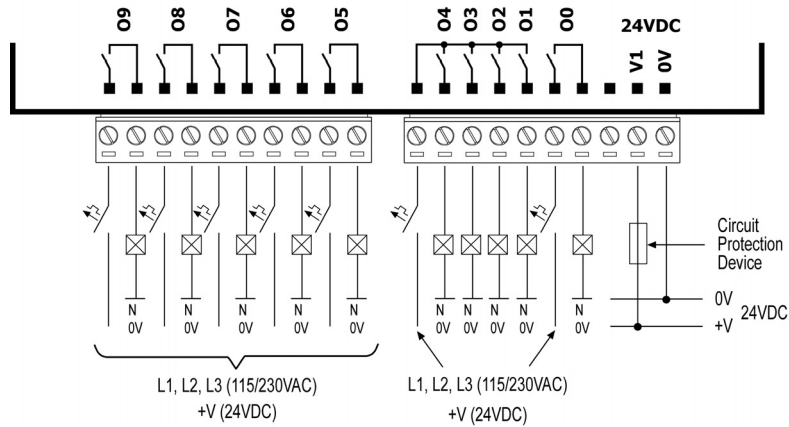

Increasing Contact Life Span

To increase life span of the relay output contacts and protect the device from potential damage by reverse EMF, connect:

- a clamping diode in parallel with each inductive DC load,
- an RC snubber circuit in parallel with each inductive AC load.

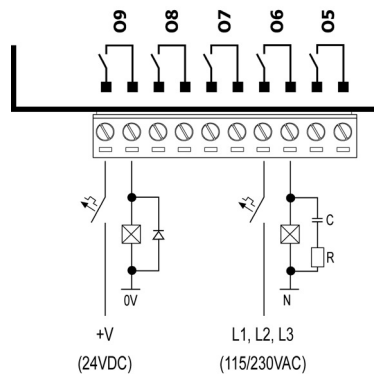

Transistor Outputs

- Note that each output can be wired separately as either npn or pnp.

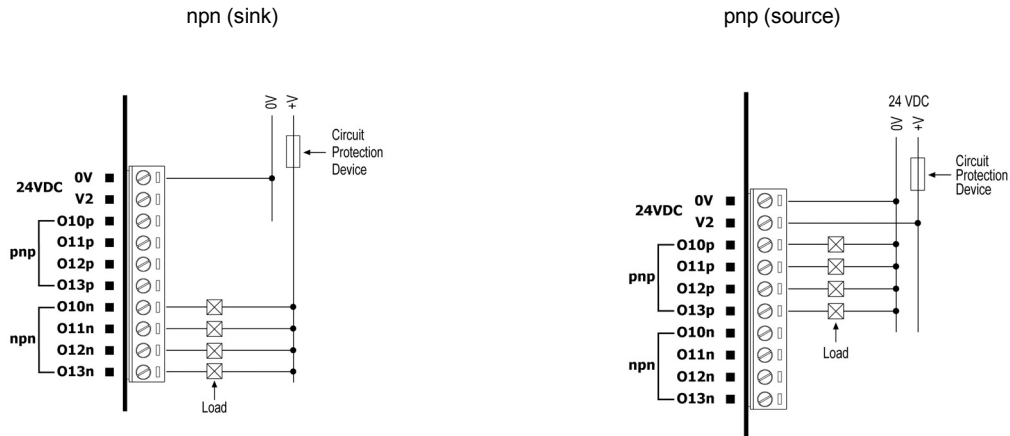

Analog Inputs

- Shields should be connected at the signal source.
- Inputs may be wired to work with either current or voltage.

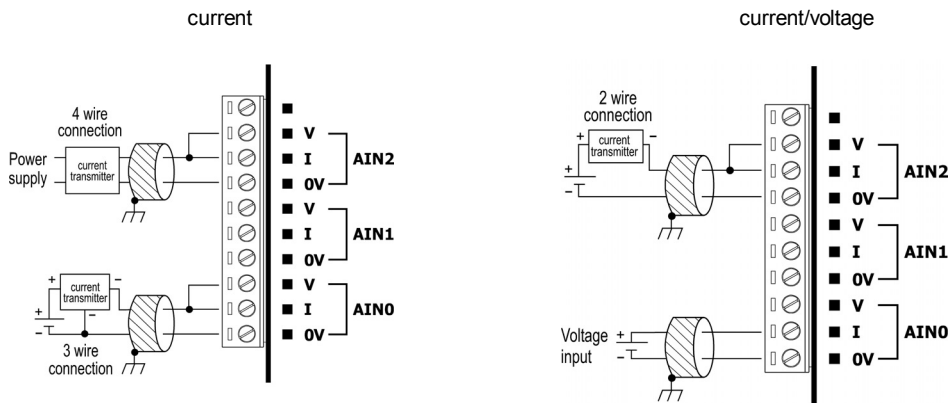

V200-18-E1 Technical Specifications

Digital Inputs

Number of inputs	16 (in two groups)
Input type	pnp (source) or npn (sink), set by jumper and wiring.
Galvanic isolation	None
Nominal input voltage	24VDC
Input voltage	
pnp (source)	0-5VDC for Logic '0' 17-28.8VDC for Logic '1'
npn (sink), voltage/current	17-28.8VDC/<1.1 mA for Logic '0' 0-5VDC/>4.3mA for Logic '1'
Input current	6mA@24VDC
Response time	10mSec typical
High speed inputs	Specifications below apply when these inputs are wired for use as a high-speed counter input/shaft encoder. See Notes 1 and 2.
Resolution	32-bit
Frequency	10kHz maximum
Minimum pulse width	40µs

Notes:

1. Inputs #0 and #2 can each function as either high-speed counter or as part of a shaft encoder. In each case, high-speed input specifications apply. When used as a normal digital input, normal input specifications apply.
2. Inputs #1 and #3 can each function as either counter reset, or as a normal digital input; in either case, its specifications are those of a normal digital input. These inputs may also be used as part of a shaft encoder. In this case, high-speed input specifications apply.

Relay Outputs

Number of outputs	10. See Note 3.
Output type	SPST-NO relay; 230VAC / 24VDC
Type of relay	Takamisawa (Fujitsu) JY-24H-K or NAIS (Matsushita) JQ1AP-24V or OMRON G6B-1114P-24VDC
Isolation	By relay
Output current	5A maximum (resistive load) 1A maximum (inductive load)
Maximum frequency	10Hz
Contact protection	External precautions required (see Increasing Contact Life Span)

Outputs' power supply

Nominal operating voltage	24VDC
Operating voltage	20.4 to 28.8VDC
Maximum current consumption	90mA@24VDC

Notes:

- Outputs #1,2,3, and 4 share a common contact. All other outputs have individual contacts.

Transistor Outputs

Number of outputs	4. Each can be individually wired as pnp (source) or npn (sink).
Output type	pnp: P-MOSFET (open drain) npn: open collector
Galvanic isolation	None
Output current	pnp: 0.5A maximum (per output) Total current: 2A maximum (per group) npn: 50mA maximum (per output) Total current: 150mA maximum (per group)
Maximum frequency	20Hz (resistive load) 0.5Hz (inductive load)
High speed output maximum frequency (resistive load). See Note 4	pnp: 2kHz npn: 50kHz
ON voltage drop	pnp: 0.5VDC maximum npn: 0.85VDC maximum
Short circuit protection	Yes (pnp only)
pnp (source) power supply	
operating voltage	20.4 to 28.8VDC
nominal operating voltage	24VDC

Notes:

- Outputs #12 and Output #13 may be used as high-speed outputs

V200-18-E1

Analog Inputs

Number of inputs	3 (single-ended)
Input range	0-10V, 0-20mA , 4-20mA
Conversion method	Successive approximation
Resolution (except at 4-20mA)	10-bit (1024 units)
Resolution at 4-20mA	204 to 1023 (820 units)
Conversion time	Synchronized to scan time
Input impedance	>100K Ω —voltage 500 Ω —current
Galvanic isolation	None
Absolute maximum rating	\pm 15V—voltage \pm 30mA—current
Full-scale error	\pm 2 LSB (0.2%)
Linearity error	\pm 2 LSB (0.2%)

Environmental

	IP20
Operating temperature	0° to 50° C
Storage temperature	-20° to 60° C
Relative Humidity (RH)	5% to 95% (non-condensing)
Dimensions (WxHxD)	138x23x123mm
Weight	219g (7.7 oz)