

USER MANUAL

FlexiLogics® PLC FL004 ECO Series



Table of Contents

INTRODUCTION	4
BEFORE YOU START.....	4
SAFETY PRECAUTIONS.....	5
PRODUCT OVERVIEW	6
PRODUCT NOMENCLATURE / ORDERING PART NUMBER	6
FRONT VIEW.....	6
PRODUCT DIMENSIONS	7
PRODUCT PERFORMANCE.....	7
PRODUCT SPECIFICATIONS	8
POWER SUPPLY	8
FL004 MEMORY	8
DIGITAL INPUTS	9
DIGITAL OUTPUTS	9
COMMUNICATION PORTS.....	10
ENVIRONMENTAL SPECIFICATIONS AND APPROVALS	10
WIRING	12
INPUT WIRING	13
OUTPUT WIRING	14
COMMUNICATION INTERFACES.....	16
COM1	16
COM2	17
USB DEVICE	17
PLC AND HMI COMMUNICATION	18
SUPPORTED PROTOCOLS	19

PRODUCT MODES	20
FORCE DOWNLOAD MODE	21
LED INDICATION FOR PRODUCT	22
SYSTEM DEFINED TAG DATABASE	23
CONFIGURATION REGISTERS	23
CONFIGURATION COILS.....	23
SINGLE PHASE SINGLE INPUT MODE SETTING	24
SINGLE PHASE TWO INPUT MODE SETTING	25
TWO PHASE TWO INPUT MODE SETTING	25
REGISTER CONFIGURATION DESCRIPTION	26
WIZARD CONFIGURATION	27
HSC.....	27
PWM INSTRUCTIONS	29
PULSE-DIRECTION OUTPUT.....	29
PULSE RAMP OUTPUT	31
PULSE OUTPUT	37
ZERO RETURN	41
ABSOLUTE POSITION CONTROL.....	50
RELATIVE POSITION CONTROL	55
REVISION HISTORY.....	62
NOTES	63

Introduction

Thank you for purchasing FL004 Product. FlexiLogics® Series Products are versatile high-performance programmable controllers with Microsoft® Windows based configuration Software.

An external powered FL series model can be used as a PLC based Automation Solution with optional built-in I/O points. The system can be expanded up to Eight I/O modules (analog and digital modules). It supports IEC61131-3 programming environment.

These products are compliant to EMC directive 2014/30/EU and LVD directive 2014/35/EU.

Before you start

- FlexiLogics®FL004 series products are Programmable Logic Controller, suitable for a variety of applications across various industries. However, the factory is not responsible or liable for any indirect or consequential damage resulting from the use of this product.
- The user should check and confirm the suitability of the product before using in any specific application.
- The diagrams and examples in this manual are included for illustration purpose only. The factory assumes no responsibility or liability regarding actual use based on these diagrams or examples.
- Reproduction of the contents of this manual, in any form (in part or in whole), is strictly prohibited.
- Following table shows various symbols that may be used in this manual to provide information regarding safety, precautions and usage of the product:

	CAUTION: Indicates specific precautions to be taken by user during installation, operation and maintenance of the product.
ATTENTION	ATTENTION: Indicates important information regarding application and functions of the product.

Safety Precautions

This section of the manual provides information which is critical regarding safety and therefore the user is advised to go through the information in detail before installing the product. User may contact the factory technical support team at suporte@dakol.com.br for any specific question(s) related to safety.



CAUTION: GENERAL PRECAUTIONS

- Do not use this product for emergency stop. A separate physical switch, outside the product must be used for any emergency stop operations.
 - Do not use the external power supply source that does not comply with the specified power requirements of the product, it may cause malfunction or permanent damage to the product.
 - Do not attempt to open, dismantle or modify the product, doing so will void the warranty.
 - This product is supplied as open-type equipment and it must be mounted suitably designed for specific environmental conditions.
 - If you connect or disconnect the USB cable with power applied to this product or any other device on USB network, and electrical arc can occur, which could cause explosion in hazardous location installations.
 - Make sure that connectors are securely tightened to properly seal the connections against leaks.
-

Product Overview

This section provides an overview of FL004 products ordering part numbers, front view, dimensional details, performance, specifications, operating conditions, environment and approvals.

These products units are compact, easy-handling block style programmable controller. It also has modular expandability.

Product Nomenclature / Ordering Part Number

FL004 series has 3 models, depending on its output type. Detail part number or ordering information is as follows:

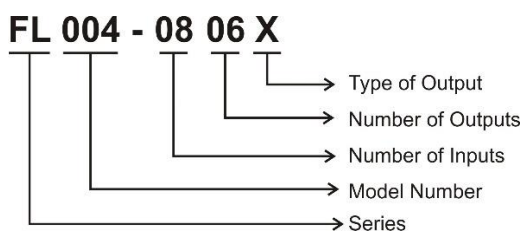

X:

R - Relay type Output

P - PNP type Output

N - NPN type Output

Front View

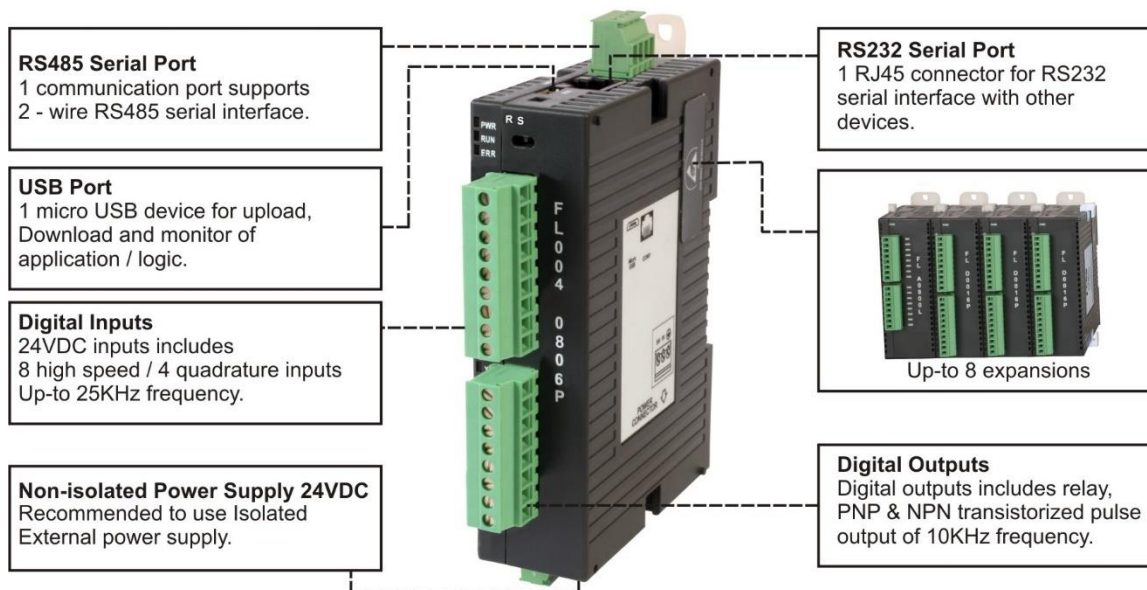

Product Dimensions

This section of the manual provides dimensional details of FL004 series products. All the dimensions shown below are measured in mm.

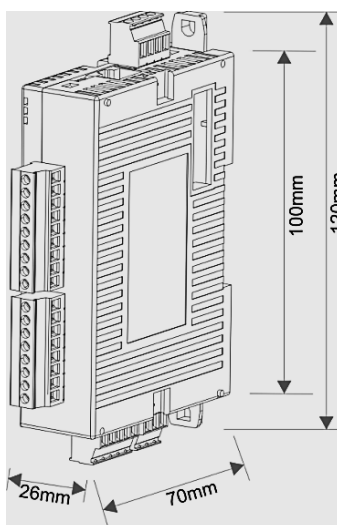

Product Performance

PLC Cycle time is as follows:

PLC Cycle Time = Input response time + Logic Execution time + Output update time

Digital Input Response Time	OFF to ON: 10ms/input ON to OFF: 10ms/input
Logic Execution Time	85.0ns/contact 342.85ns/coil 533.33ns/16bit transfer 523.80ns/16bit signed addition
Digital Output Update Time	Relay model: about 10ms/output NPN/PNP model: OFF to ON: 60μs ON to OFF: 10μs

Product Specifications

Power Supply

Power Supply	24VDC, 250mA
Power Consumption (With Expansions)	5W@24VDC
Permissible range	20.4 to 28.8VDC

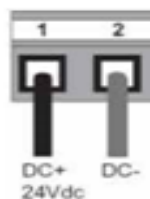

CAUTION: POWER SUPPLY PRECAUTION

- Keep distance between High and Low voltage line.

FL004 Memory

Total Memory	124KB (Application Memory 44KB + Logic Memory 80KB)
Program Capacity	13K Steps

Digital Inputs

Input Signal	DC Input Bi-directional
Total Channels	8
High Speed Channels	8
Isolation	3.7KV
High Speed Inputs	2 (25KHz), 8 (10KHz)
Quadrature Inputs	2 (10KHz), 4 (5KHz)
Level 0	0 to 5VDC
Level1	15 to 30VDC
Number of Input channels	8 (X0, X1..... X7)

Digital Outputs

Total Channels	6		
Output Type	PNP	Relay	NPN
Nominal Load Current	0.5A/channel at 24VDC	2A at 230VAC, 5A/common	0.5A/channel at 24VDC
High Speed Output	Up-to 10KHz each (3 Channels with Dir.)	-	Up-to10KHz each (3 Channels with Dir.)

Communication Ports

Serial	2
Type	One 3.81 pitch PBT RS485 (2-Wire), One RJ45 RS232
USB	1
Type	Micro USB (Device)

General Specifications

Control Method	Stored program, cyclic scan system
I/O Processing Method	Batch I/O (refresh) Direct I/O instruction available
Program Language	IEC61131-3 (LD, SFC, IL, FBD, ST)
I/O Expansion	Up to 8 Slots (Digital and Analog)
Serial Communication	One 3.81 pitch PBT RS485 (2-Wire), One RJ45 RS232
Weight	Approx. 150gms
Dimensions (H x W x D)	100mm(H) X 26mm(W) X 70mm(D)

Environmental Specifications and Approvals

Feature	Specifications
Operating Temperature	0 to 55°C
Storage Temperature	-20 to 85°C
Relative Humidity	10 to 90% non-condensing
Shock	IEC 60068-2-2-6 25g, 11ms, 6 shocks per axis, total 18 shocks (X, Y,Z)
Vibration	IEC 60068-2-6, 5 to 150Hz, 3g peak (X, Y, Z)

EMC	EN 55011 :2009/A1 :2010 EN 61131-2 :2007 EN 61000-6-2 :2005/AC :2005 EN 61000-6-4 : 2007/A1 :2011
CE	Yes
RoHS	Yes

Wiring

Prior to performing any wiring, always turn the power off. In some special circumstance, if the user needs to perform wiring to input points while power is on, always stop the PLC. Otherwise, output points may be activated and cause accidently damage to the systems.

FL004 series required isolated 24VDC power supply. When wiring DC power, the 'positive' cable should be connected to the '+' terminal and the negative should be connected to the '-' terminal. At no time should the power supply terminals be connected to any other terminal on the PLC.

When DC voltage is supplied to the PLC, make sure the power is at terminals 24VDC and 0V.

Input PLCs have two modes of operation: SINK and SOURCE.

Sinking and Sourcing are terms used to define the control of direct current flow in a load. Sinking digital I/O (input/output) provides a grounded connection to the load. Sourcing digital I/O provides a voltage source to the load.

- **Sink = Current flows into the common terminal S/S**
- **Source = Current flows out of common terminal S/S**

Below are circuit diagrams showing both the sinking and sourcing inputs.

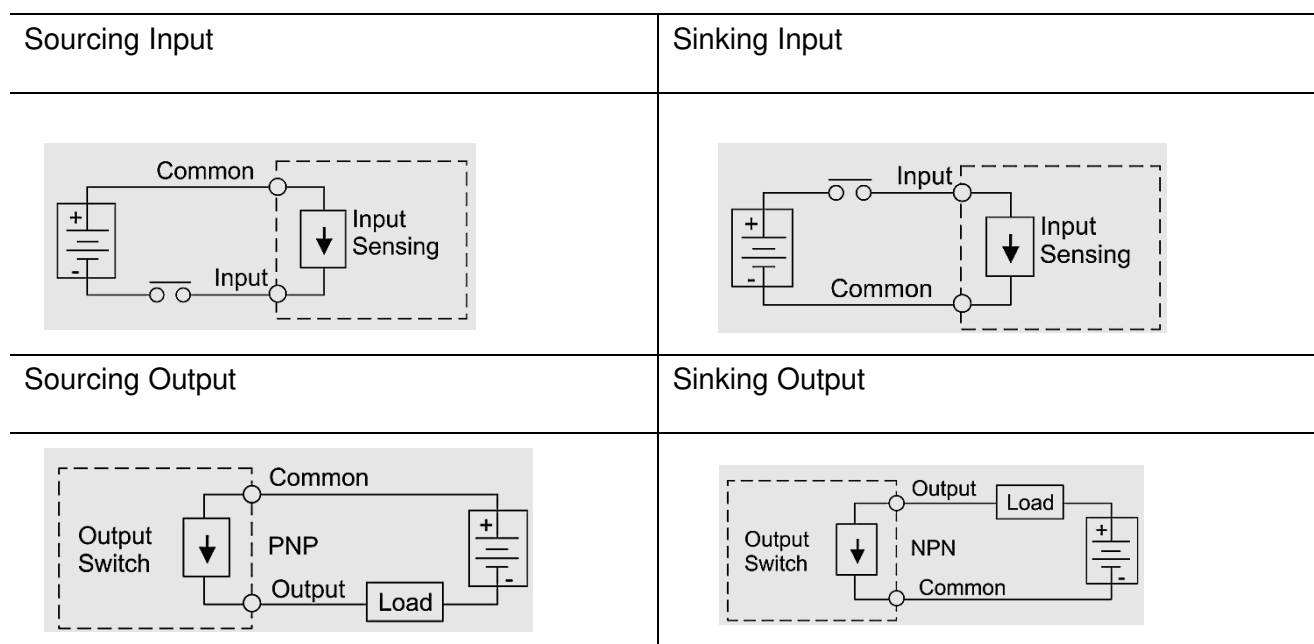

Input Wiring

Digital Inputs

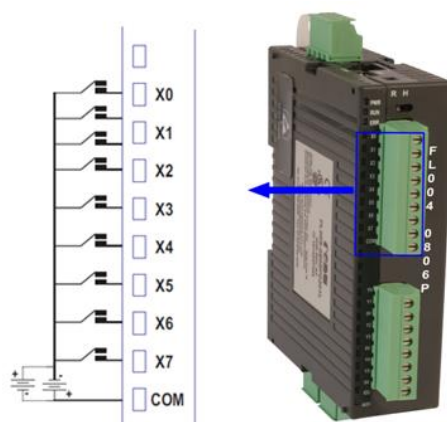

HSC Inputs: Single Phase counter

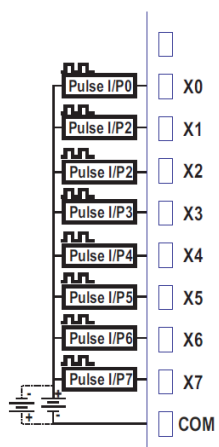

Quadrature

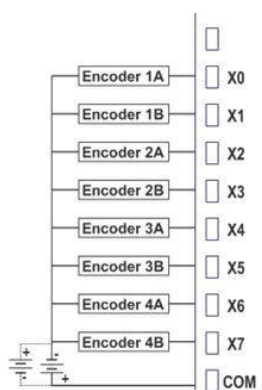

Output Wiring

Digital Outputs: P-Type

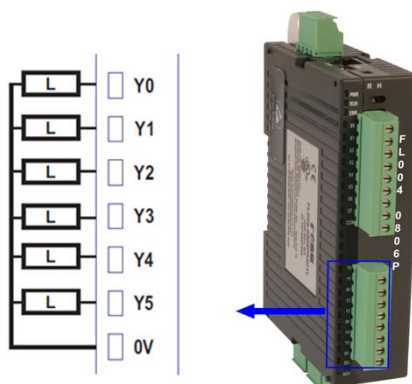

Digital Outputs: N-Type

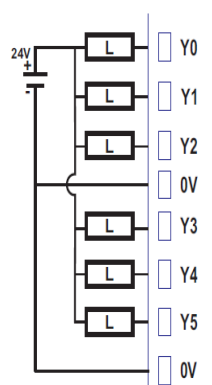

Digital Outputs: R-Type

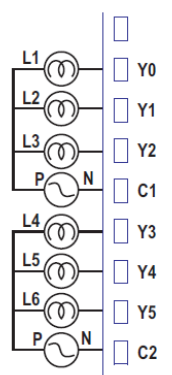

PWM Output: P-Type

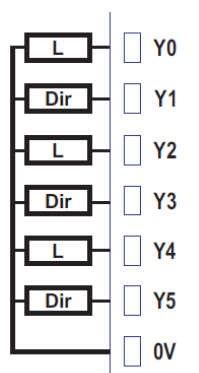

PWM Output: N-Type

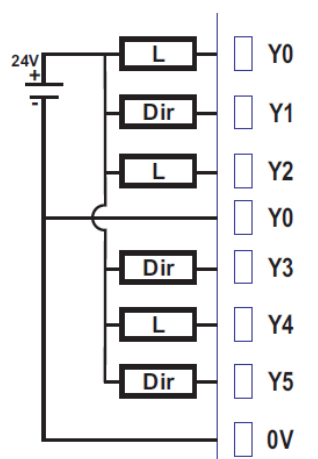

Communication Interfaces

This section of the manual gives detail information regarding various communication interfaces supported by FL4 series products, including communication interfaces between FL4 and any other device or third-party device, interfaces for programming and monitoring.

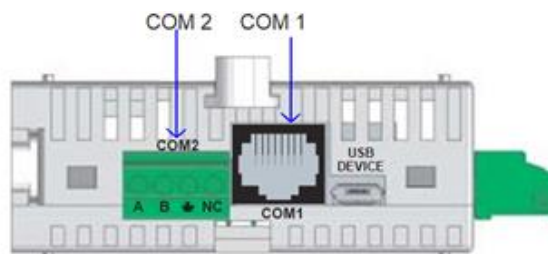

COM1

[RJ45 Type]: RS232

For Upload/Download/Communication monitoring

Part Number: IBM-H-005-00

[Note: IBM-H-005-00: 2M cable, IBM-H-005-05: 5cable, IBM-H-005-10: 10M cable]

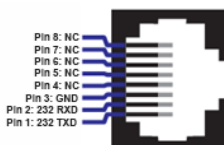

Pin number	Signal
1	232 TXD
2	232RXD
3	GND
4	NC
5	GND
6	NC
7	NC
8	NC
9	NC

COM2

2 wire RS485 for communication

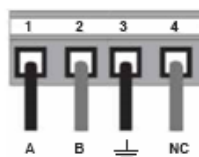

Pin number	Signal
1	TX+/RX+
2	TX-/RX-
3	GND

USB Device

For Upload/Download/Monitoring

Part number: PC-USBAB-00-Micro

[Note: PC-USBAB-00: 2M cable, PC-USBAB-05: 5M cable, PC-USBAB-10: 10M cable]

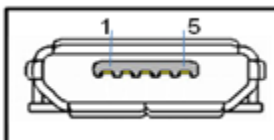

Pin number	Signal
1	VCC
2	D-
3	D+
4	NC
5	GND

PLC and HMI Communication

For communication between PLC and HMI on Port 2, Pin description is as follows:

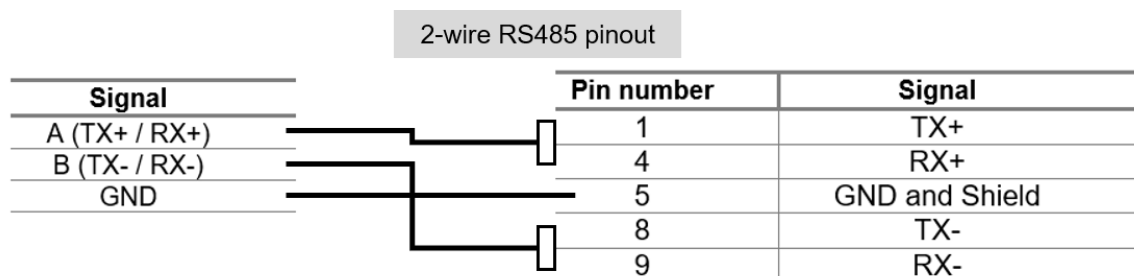

Supported Protocols

ABB PLCS

Allen Bradley DF1

Baldor

Danfoss Drive

Delta PLCs

Flexi Logics Slave Driver

Flexi Logics Master Driver

FL Smidth Loadcell

GE SNP

GE SNP-X

Idec PLCS

LG Master K Series PLC

LG Master K 300S

Mitsubishi FX

Mitsubishi Q Series PLCS(Serial)

Fatek PLC

Modbus ASCII (Unit as Master)

Modbus RTU (Unit as Master)

Modbus ASCII (Unit as Slave)

Omron Inverter Memo Bus

Omron Host Link

Panasonic FP Series

Siemens Micromaster Driver(USS)

Toshiba (Link Port)Series PLCs

Toshiba Inverters PLCs

Toshiba T series

TriPLC

Twido PLCs

Unitelway PLCs

Universal Serial Driver(ASCII)

Product Modes

These products have three basic operation modes, the RUN mode, the HALT mode and the ERROR mode. It also has the RUN-F modes mainly for system checking.

RUN:

The RUN mode is a normal control-operation mode.

In this mode, the base model reads input signals, executes the user program, and updates the output devices according to the user program. In the RUN mode, FlexiLogics® unit executes the user's ladder program logic, which is the basic operation of a PLC. In this mode task defined in the application are also executed.

EEPROM write are possible while the FlexiLogics® base is in the RUN mode.

HALT:

The HALT mode is a STOP mode.

In this mode, user program execution is stopped, and all outputs are brought to zero (0).

Program loading into the FlexiLogics® base unit is possible in the HALT mode.

ERROR:

The ERROR mode is a shutdown mode because of self-diagnosis.

The FlexiLogics® base model enters the ERROR mode if internal error is detected by self-diagnosis. In this mode, program execution is stopped, and all outputs are brought to "Error State Output Condition" defined in the application. The cause of the shutdown can be confirmed by connecting the programming tool.

To exit from the ERROR mode, execute the Error Reset command from the programming tool, or cycle power off and then on again.

RUN-F:

The RUN-F mode is a forced RUN mode provided for program checking.

This mode is effective when using the expansion, I/O's. Different from the normal RUN mode, the RUN-F mode allows operation even if the registered I/O modules are not actually mounted. In this mode the physical outputs are not updated, only the registers are updated.

[Note: For more information refer Force Download Mode given below.]

Boot Block:

RUN and ERROR LED blinking in sink 500ms ON/OFF, the system is in Boot Block mode.

The operation modes are switched by the mode control switch provided on the FlexiLogics® base model and the mode control commands issued from the programming tool.

Force Download Mode

In case the PLC is not responding for the firmware download command and when it does not allow the further download in the unit, PLC can be driven in the Force download mode. Follow the following step to enter the force download mode.

We can do it by using 2 ways:

1. Using RS232 Cable

1. Power off the unit.
2. Remove all communication cables. No need to remove USB cable.
3. Short the pin 2 and 8 of Com1 (RJ45). (Prepare the special RJ cable for this).
4. Turn the Run/Halt switch to halt position.
5. Power on the unit.
6. Wait for 10sec.
7. Unit enters the Force download mode. The indication is that the Run and Error LEDs start blinking at 1sec interval.
8. Remove the short of pin 2 and 8 of com1 RJ45.
9. Download the firmware first, using USB or Com1 RS232 cable.
10. The device remains in the “Force Download Mode” only for one minute. After one minute it exits from this mode and executes the firmware if it is valid. This is indicated by turning off Run and Error LEDs.

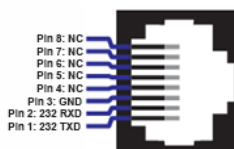

2. Using RS485 Cable

1. Power off the unit
2. Remove all communication cables. No need to remove USB cable.
3. Short the pin A and GND (\oplus) of Com2 (4-pin PBT).

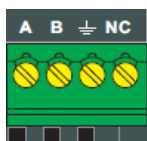

4. Turn the Run/Halt switch to halt position.
5. Power on the unit.
6. Wait for 10sec.
7. Unit enters the Force download mode. The indication is that the Run and Error LEDs start blinking at 1sec interval.
8. Remove the short pin A and GND (\oplus) of Com2 (4-pin PBT).
9. Download firmware first, using USB or Com1 RS232 cable.
10. The device remains in the “Force Download Mode” only for one minute. After one minute it exits from this mode and executes the firmware if it is valid.

LED Indication for Product

LED	Color	Status
Run	GREEN	ON: Unit is in RUN mode
		OFF: Unit is not in RUN mode (unit may be in HALT, HOLD, ERROR, etc.)
Error	GREEN	ON: Unit is in ERROR mode.
		OFF: Unit is not in ERROR mode.
Power	GREEN	ON: If supply voltage 24VDC is given

System Defined Tag Database

Configuration Registers

Configuration Registers	Tag Name	Tag Type	Type (R/W/RW)	FL004-0806P/N	FL004 - 0806R
MW0000	PLC_Mode_Control	WORD	Read/Write	Yes	Yes
MW0003	RUN_STOP_Switch_Control_Retentive	WORD	Read Only	Yes	Yes
MW0030	System_Timer_Coils	WORD	Read Only	Yes	Yes
MW0006	DI_Filter_Constant_X0_to_X7_mS	WORD	Read/Write	Yes	Yes
MW0031	User_Interrupt_program_Status_Flags	WORD	Read/Write	Yes	Yes
MW0032	Always_ON_OFF_Bits	WORD	Read/Write	Yes	Yes
MW0001	Error_Flag_1	WORD	Read/Write	Yes	Yes
MW0002	Error_Flag_2	WORD	Read/Write	Yes	Yes

Configuration Coils

Configuration Coil	Name	Tag	Type (R/W/RW)	FL004 0806P/N	FL004-0806R
M00016	CPU_error	BOOL	Read Only	Yes	Yes
M00017	IO_error	BOOL	Read Only	Yes	Yes
M00018	Program_error	BOOL	Read Only	Yes	Yes
M00021	Clock_calendar_illegal_value_warning	BOOL	Read Only	No	No
M00022	Retentive_data-invalid_warning	BOOL	Read Only	Yes	Yes
M00027	Watchdog_timer_error	BOOL	Read Only	Yes	Yes
M00028	IO_Bus_error	BOOL	Read Only	Yes	Yes
M00029	IO_Mismatch_error	BOOL	Read Only	Yes	Yes
M00031	IO_Communication_error	BOOL	Read Only	Yes	Yes
M00033	Ladder_scan_time_error	BOOL	Read Only	Yes	Yes
M00480	System_timer_coil_for_100_millisecond_interval	BOOL	Read Only	Yes	Yes
M00481	System_timer_coil_for_200_millisecond_interval	BOOL	Read Only	Yes	Yes
M00482	System_timer_coil_for_400_millisecond_interval	BOOL	Read Only	Yes	Yes
M00483	System_timer_coil_for_800_millisecond_interval	BOOL	Read Only	Yes	Yes
M00484	System_timer_coil_for_1_sec_interval	BOOL	Read Only	Yes	Yes
M00485	System_timer_coil_for_2_sec_interval	BOOL	Read Only	Yes	Yes
M00486	System_timer_coil_for_4_sec_interval	BOOL	Read Only	Yes	Yes
M00487	System_timer_coil_for_8_sec_interval	BOOL	Read Only	Yes	Yes
M00496	Timer_interrupt_ladder_execution_status	BOOL	Read Only	Yes	Yes
M00497	IO1_interrupt_execution_status	BOOL	Read Only	No	No
M00498	IO2_interrupt_execution_status	BOOL	Read Only	No	No

Single Phase Single Input Mode Setting

Channels	CH-1	CH-2	CH-3	CH-4	CH-5	CH-6	CH-7	CH-8
Physical Input	X0	X1	X2	X3	X4	X5	X6	X7
Config. Reg	MW0010	MW0020	MW0040	MW0046	MW1713	MW1718	MW1724	MW1729
Counter Reg	MW0011	MW0021	MW0041	MW0047	MW1714	MW1719	MW1725	MW1730
Preset Reg	MW0013	MW0023	MW0043	MW0049	MW1716	MW1721	MW1727	MW1732
Rate Reg	MW1734	MW1740	MW1746	MW1752	MW1758	MW1764	MW1770	MW1776
Rate Span Reg	MW1736	MW1742	MW1748	MW1754	MW1760	MW1766	MW1772	MW1778
Pulses Per Scan Reg	MW1738	MW1744	MW1750	MW756	MW1762	MW1768	MW1774	MW1780
HSC Enable Bit	M00240	M00400	M00720	M00723	M00246	M00406	M00252	M00412
HSC Reset Bit	M00241	M00401	M00721	M00724	M00247	M00407	M00253	M00413
HSC Preset Reach Bit	M00242	M00402	M00722	M00725	M00248	M00408	M00254	M00414
Rate Span Error Bit	M00244	M00404	M00727	M00730	M00250	M00410	M00733	M00415
HSC Physical Reset	X1	X0	X3	X2	X5	X4	X7	X6
Force Output	Y0	Y1	Y2	Y3	Y4	Y5	NA	NA
HSC Dir Control Bit	M00096	M00097	M00098	M00099	M00100	M00101	M00102	M00103

Single Phase Two Input Mode Setting

MODE	1.UP-DOWN DIRECTION MODE				2.UP-DOWN MODE			
	CH-1	CH-3	CH-5	CH-7	CH-1	CH-3	CH-5	CH-7
Physical Input	X0: Pulses	X2: Pulses	X4: Pulses	X6: Pulses	X0: Up Count	X2: Up Count	X4: Up Count	X6: Up Count
Direction Input	X1: Direction	X3: Direction	X5: Direction	X7: Direction	X1: Down Count	X3: Down Count	X5: Down Count	X7: Down Count
Config. Reg	MW0010	MW0040	MW1713	MW1724	MW0010	MW0040	MW1713	MW1724
Counter Reg	MW0011	MW0041	MW1714	MW1725	MW0011	MW0041	MW1714	MW1725
Preset Reg	MW0013	MW0043	MW1716	MW1727	MW0013	MW0043	MW1716	MW1727
Rate Reg	MW1734	MW1746	MW1758	MW1770	MW1734	MW1746	MW1758	MW1770
Rate Span Reg	MW1736	MW1748	MW1760	MW1772	MW1736	MW1748	MW1760	MW1772
Pulses Per Scan Reg	MW1738	MW1750	MW1762	MW1774	MW1738	MW1750	MW1762	MW1774
HSC Enable Bit	M00240	M00720	M00246	M00252	M00240	M00720	M00246	M00252
HSC Reset Bit	M00241	M00721	M00247	M00253	M00241	M00721	M00247	M00253
HSC Preset Reach Bit	M00242	M00722	M00248	M00254	M00242	M00722	M00248	M00254
Rate Span Error Bit	M00244	M00727	M00250	M00733	M00244	M00727	M00250	M00733
HSC Physical Reset	X4	X6	X0	X2	X4	X6	X0	X2
Force Output	Y0	Y2	Y4	NA	Y0	Y2	Y4	NA
HSC Dir Control Bit	NA	NA	NA	NA	NA	NA	NA	NA

Two Phase Two Input Mode Setting

Channels	CH-1	CH-3	CH-5	CH-7
Physical Input	X0: A-Phase	X2: A-Phase	X4: A-Phase	X6: A-Phase
Direction Input	X1: B-Phase	X3: B-Phase	X5: B-Phase	X7: B-Phase
Config. Reg	MW0010	MW0040	MW1713	MW1724
Counter Reg	MW0011	MW0041	MW1714	MW1725
Preset Reg	MW0013	MW0043	MW1716	MW1727
Rate Reg	MW1734	MW1746	MW1758	MW1770
Rate Span Reg	MW1736	MW1748	MW1760	MW1772
Pulses Per Scan Reg	MW1738	MW1750	MW1762	MW1774
HSC Enable Bit	M00240	M00720	M00246	M00252
HSC Reset Bit	M00241	M00721	M00247	M00253
HSC Preset Reach Bit	M00242	M00722	M00248	M00254
Rate Span Error Bit	M00244	M00727	M00250	M00733
HSC Physical Reset	X4	X6	X0	X2
Force Output	Y0	Y2	Y4	NA
HSC Dir Control Bit	NA	NA	NA	NA

Register Configuration Description

15	14	13	12	11	10	9	8	7	6	5	4	3	2	1	0
Both Edge selection	Preset Selection	Rate Enable Selection	Execute Logic Selection	Frequency Mode	Reset Output	Force Output Configuration	Force Mode Selection	Quadrature Mode	Enable Selection	Direction Control	Edge Selection	Mode Selection			

Bit No.	Function	Description
15	Both Edge Selection	If Single Phase Input 0: Rising/Falling Control by Bit-3 (1 - Time Frequency Mode) 1: Both Edges Rising & Falling (2 - Time Frequency Mode)
14	Preset Selection	0: Preset Value in MW Preset Register 1: Constant Preset Value
13	Rate Enable Selection	0: Rate Functionality Disable 1: Rate Functionality Enable
12	Execute Logic Selection	Preset Reached Action 0: Execute Logic Disable 1: Execute Logic Enable
10	Reset Selection	0: Reset by Bit 1: Reset by Hardware Pin
9	Force Output Configuration	If Force output Enable 0: Force Output ON When Preset Reach 1: Force Output OFF When Preset Reach
8	Force control Selection	Preset Reached Action 0: Force Output Disable 1: Force Output Enable if Execute Logic Enable Force Output Don't care
7 & 6	Quadrature Mode	If Two Phase Two Input Mode, Select 00: 1X Mode 01: 2X Mode 10: 4X Mode
5	Enable Selection	0: Enable by Bit 1: Enable at Power ON
4	Direction Control	0: Up Counting 1: Down Counting
3	Edge Selection	0: Falling Edge 1: Rising Edge
2 to 0	Mode Selection	000: Normal Mode 010: Single Phase Single Input Mode 011: Two Phase Two Input Mode (Quadrature) 100: Single Phase Two Input Up Down Direction Mode 101: Single Phase Two Input Up Down Mode

Wizard Configuration

HSC

Wizards are used to set some parameters as follows:

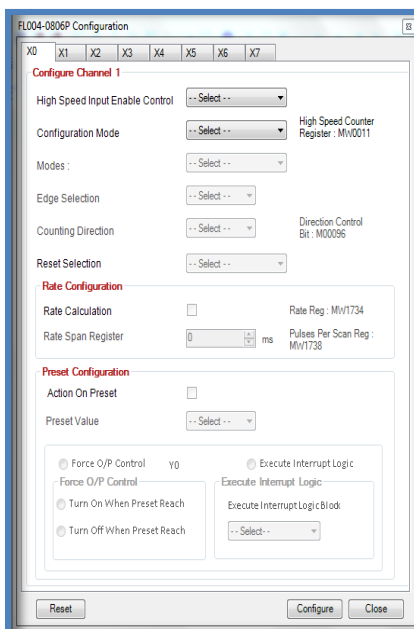

Configurations	Descriptions
High Speed Input Enable Control	There are Two Selections under this option: 1. At Power On: No need to Enable Counter Bit, it counts when Pulses at Inputs Pin. 2. Bit Control: Dedicated Bit Provided to Enable or Disable Counting.
Configuration Mode	There are Three Selection under this option used to select mode of HSC: 1. Single Phase Input 2. Single Phase Two Input 3. Quadrature for Description of this mode, refer FL Manual. for New modes refer New mode Description tab of this sheet.
Modes	This Option is used to select sub modes of above configurations modes. This is applicable for Single Phase Two Inputs & Quadrature Modes.

Edge Selection	<p>There is Three Selection under this option:</p> <ol style="list-style-type: none"> 1.Rising 2.Falling 3.Rising & falling <p>Previously in HSC there are only two edge selections modes, Now we are included new Edge Selection mode is Rising & Falling. Rising & Falling is like a two times Freq Modes. Counter Counts on both Rising & Falling Edges of Input Pulses. Edge Selection Option is available for Single Phase Input & Single Phase Two Inputs modes, Not Available for Quadrature mode.</p>
Counting Direction	<p>This option is used to select Up counting & Down Counting modes this selection is available only for Single Phase Input Mode. New modification has done in the Counting Direction is, Dedicated Bit is assigned to change Counting Direction at runtime, When Bit is '0': up Counting & '1': Down counting.</p>
Reset Selection	<p>There are two Options to reset counter:</p> <ol style="list-style-type: none"> 1. Internal Reset Bit: Dedicated coil is assigned for channels to reset counter if it is '1' then counter gets reset. 2. External Physical Reset: Dedicated Hardware Input Pin is assigned for channels to reset counter for channels in different modes (Refer HSC Details tab).
Rate Configuration	Configure settings related to the Rate Functionality.
Rate Calculation	If this is select, then Rate Functionality is Enable otherwise it is Disable.
Rate Span Register	This Register is used to give Span in ms to calculate Rate. Refer Span calculation tab to calculate Span Value.
Preset Configuration	Configure Settings related to the Preset Functionality.
Preset Value	<p>There are Two ways to Give Preset Value.</p> <ol style="list-style-type: none"> 1. Constant Value 'K'. Does not change Runtime 2. MWxxx – We provides Tag for Preset Value
Action to Be Performed after Preset reach	<p>There are Two actions, one of which needs to be performed on preset reach:</p> <ol style="list-style-type: none"> 1. Force Output Control: Dedicated Force Output is assigned for HSC channels. 2. Execute Logic: You need to create blocks in Hardware Interrupt under logic block. Created blocks appears in the selection window for execute block on Preset reach. Select block will executed only once after Preset reach. Logic Execution Time should not be large than Input Pulses.

PWM Instructions

1. Pulse-Direction Output

Function:

When Enable Input is ON, this instruction Out Pulses on Selected High-Speed Output Channel at entered Frequency.

Direction output Status is depending on the Sign of entering Frequency and PulseOp_Dir_CoOrdinate_Change_CHx Bit.

Execution Condition

Condition	Action
The rung-condition-in is false	The rung-condition-out is false
The rung-condition-in is true	The rung-condition-out is set to true only if Enable is true

Operands

Operands	Type	Descriptions
Enable	BOOL	BOOL Value. Enable or Disable instruction
Channel_No	USINT	Enter Channel number e.g. Enter '1' for CH-1(Y0- Pulses, Y1- Dir)
Frequency	DINT	Range of Frequency is depending on Product. If Entered freq is more/less than Specified freq then Freq_Setting_Error_Flag will be Set and Instruction will work at limiting frequency of that product.
CH_Error	BOOL	If Entered Channel_No is more/less than the Pulse_Dir channels that product have, then CH_Error is Set.

Example:

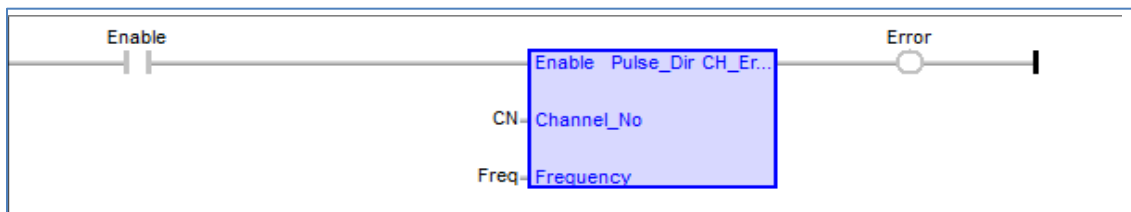

if Enable is ON, Pulse_Dir Instruction will Execute

if CN = 1 & Freq = 1000 then Pulse will be out at Y0 & Y1 will be Low

if CN = 1 & Freq = -1000 then Pulse will be out at Y0 & Y1 will be High

if CN is more/less than the Pulse_Dir channels that product have then Error is ON

Associated Special Tags/Bits

Tags/Bits	Tag/Bit Name	Description
M00104	PulseOp_Dir_CoOrdinate_Change_CH1	When this bit is Set, Reverse the direction conditions of direction output Y1. if 'FALSE': +ve Freq, Y1-OFF & -ve Freq, Y1-ON if 'TRUE': +ve Freq, Y1-ON & -ve Freq, Y1-OFF
M00105	PulseOp_Dir_CoOrdinate_Change_CH2	When this bit is Set, Reverse the direction conditions of direction output Y3. if 'FALSE': +ve Freq, Y3-OFF & -ve Freq, Y3-ON if 'TRUE': +ve Freq, Y3-ON & -ve Freq, Y3-OFF
M00106	PulseOp_Dir_CoOrdinate_Change_CH3	When this bit is Set, Reverse the direction conditions of direction output Y5. if 'FALSE': +ve Freq, Y5-OFF & -ve Freq, Y5-ON if 'TRUE': +ve Freq, Y5-ON & -ve Freq, Y5-OFF
M00107	PulseOp_Dir_CoOrdinate_Change_CH4	When this bit is Set, Reverse the direction conditions of direction output Y7. if 'FALSE': +ve Freq, Y7-OFF & -ve Freq, Y7-ON if 'TRUE': +ve Freq, Y7-ON & -ve Freq, Y7-OFF
M00112	Pulse_Output_Pause_CH1	If This Bit is 'TRUE' - Stop Pulses immediately of channel 1 - Y0. 'FALSE' - Resume and starts Pulse out at Y0
M00113	Pulse_Output_Pause_CH2	If This Bit is 'TRUE' - Stop Pulses immediately of channel 2 - Y2. 'FALSE' - Resume and starts Pulse out at Y2
M00114	Pulse_Output_Pause_CH3	If This Bit is 'TRUE' - Stop Pulses immediately of channel 3 - Y4. 'FALSE' - Resume and starts Pulse out at Y4
M00115	Pulse_Output_Pause_CH4	If This Bit is 'TRUE' - Stop Pulses immediately of channel 4 - Y6. 'FALSE' - Resume and starts Pulse out at Y6.
M00116	Pulse Output Pause Status CH1	Shows the status of ' Pulse Output Pause CH1'.
M00117	Pulse Output Pause Status CH2	Shows the status of ' Pulse Output Pause CH2'.
M00118	Pulse Output Pause Status CH3	Shows the status of ' Pulse Output Pause CH3'.
M00119	Pulse Output Pause Status CH4	Shows the status of ' Pulse Output Pause CH4'.
M00819	Frequency_Setting_error_flag_CH1	'TRUE' - Entered frequency is out of range for channel 1. 'FALSE' - Entered frequency is within range for channel 1.
M00835	Frequency_Setting_error_flag_CH2	'TRUE' -Entered frequency is out of range for channel 2. 'FALSE' - Entered frequency is within range for channel 2.
M00851	Frequency_Setting_error_flag_CH3	'TRUE' -Entered frequency is out of range for channel 3. 'FALSE' - Entered frequency is within range for channel 3.
M00859	Frequency_Setting_error_flag_CH4	'TRUE' -Entered frequency is out of range for channel 4.

		'FALSE'- Entered frequency is within range for channel 4.
MW0068	Elapsed_Value_CH1	This tag shows current pulses out at channel 1. (Y0 : Pulses, Y1 : Direction) if Freq is +ve: tag shows incrementing pulse count Freq is -ve: tag shows decrementing pulse count
MW0084	Elapsed_Value_CH2	This tag shows current pulses out at channel 2. (Y2 : Pulses, Y3 : Direction) if Freq is +ve: tag shows incrementing pulse count Freq is -ve : tag shows decrementing pulse count
MW1709	Elapsed_Value_CH3	This tag shows current pulses out at channel 3. (Y4 : Pulses, Y5 : Direction) if Freq is +ve: tag shows incrementing pulse count Freq is -ve : tag shows decrementing pulse count
MW1791	Elapsed_Value_CH4	This tag shows current pulses out at channel 4. (Y6 : Pulses, Y7 : Direction) if Freq is +ve: tag shows incrementing pulse count Freq is -ve: tag shows decrementing pulse count

2. Pulse Ramp Output

Function:

When Enable Input is ON, This Instruction Out Specified Number of Pulses on Selected High-Speed Output Channel with trapezoidal profile.

Executive Condition

Condition	Action
The rung-condition-in is false	The rung-condition-out is false
The rung-condition-in is true	The rung-condition-out is set to true only if Enable is true

Operands

Operands	Type	Descriptions
Enable	BOOL	BOOL Value Enable or Disable instruction
Channel_No	USINT	Enter Channel number e.g. Enter '1' for CH-1(Y0-Pulses, Y1-Dir)
Start_End_Freq	UDINT	Start_End_Freq of Pulse Output i.e. Min Freq. If Entered freq is more/less than Specified freq then Freq_Setting_Error_Flag will be Set and Instruction will work at lower/upper bound of freq as Start_End_Freq.
Pulse_Op_Freq	UDINT	Pulse Output Frequency i.e. Max Freq. If Entered freq is more/less than Specified freq then Freq_Setting_Error_Flag will be Set and Instruction will work at lower/upper bound of freq as Start_End_Freq
Acc_Time_mS	UINT	Acceleration Time in mSec. If Entered time is more/less than specified range, then Acceleration_Time_Setting_error_flag will be set and instruction will work at lower/upper bound of Acceleration Time.

		For FL004-Series: unit is 1mSec FL005 & FL055 Series: unit is 10mSec.
Dec_Time_mS	UINT	Deceleration Time in mSec. If Entered time is more/less than specified range, then Deceleration_Time_Setting_error_flag will be set and instruction will work at lower/upper bound of Deceleration Time. For FL004-Series : unit is 1mSec :: FL005 & FL055 Series : unit is 10mSec.
NoOfPulses	UDINT	Number of Pulses.
CH_Error	BOOL	If Entered Channel_No is more/less than the Pulse_Ramp channels that product have , then CH_Error is Set.

Example

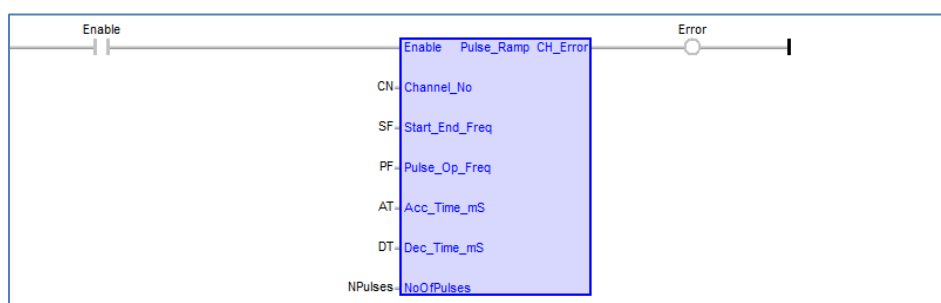

If CN = 1, Enable is ON & Configured Specified Input Parameters Then Pulses will be out with Trapezoidal Profile on Selected Channel.

Channel_Num, Start_End_Freq, Pulse_Op_Freq, Acc_Time_mS, Dec_Time_mS & NoOfPulses are Entered then trapezoidal Profile will generate.

Trapezoidal_Min_Pulse_Count_Register_CHx shows the minimum pulses required to generate trapezoidal profile.

Trapezoidal_Min_Pulse_Count is calculated by using Start_End_Freq, Pulse_Op_Freq, Acc_Time_mS, Dec_Time_mS by PLC internally and shows count in Trapezoidal_Min_Pulse_Count_Register_CHx tag.

Associated Special Tags/Bits

Tags/Bits	Tag/Bit Name	Description
M00104	PulseOp_Dir_CoOrdinate_Change_CH1	When this bit is Set, Reverse the direction conditions of direction output Y1. if 'FALSE': +ve Freq, Y1-OFF & -ve Freq, Y1-ON if 'TRUE': +ve Freq, Y1-ON & -ve Freq, Y1-OFF
M00105	PulseOp_Dir_CoOrdinate_Change_CH2	When this bit is Set, Reverse the direction conditions of direction output Y3. if 'FALSE': +ve Freq, Y3-OFF & -ve Freq, Y3-ON if 'TRUE' : +ve Freq, Y3-ON & -ve Freq, Y3-OFF
M00106	PulseOp_Dir_CoOrdinate_Change_CH3	When this bit is Set, Reverse the direction conditions of direction output Y5. if 'FALSE': +ve Freq, Y5-OFF & -ve Freq, Y5-ON

		if 'TRUE' : +ve Freq, Y5-ON & -ve Freq, Y5-OFF.
M00107	PulseOp_Dir_CoOrdinate_Change_CH4	When this bit is Set, Reverse the direction conditions of direction output Y7. if 'FALSE': +ve Freq, Y7-OFF & -ve Freq, Y7-ON. if 'TRUE': +ve Freq, Y7-ON & -ve Freq, Y7-OFF.
M00112	Pulse_Output_Pause_CH1	If This Bit is 'TRUE' - Stop Pulses immediately of channel 1 - Y0. 'FALSE' - Resume and starts Pulse out at Y0.
M00113	Pulse_Output_Pause_CH2	If This Bit is 'TRUE' - Stop Pulses immediately of channel 2 - Y2. 'FALSE' - Resume and starts Pulse out at Y2.
M00114	Pulse_Output_Pause_CH3	If This Bit is 'TRUE' - Stop Pulses immediately of channel 3 - Y4. 'FALSE' - Resume and starts Pulse out at Y4.
M00115	Pulse_Output_Pause_CH4	If This Bit is 'TRUE' - Stop Pulses immediately of channel 4 - Y6. 'FALSE' - Resume and starts Pulse out at Y6.
M00116	Pulse_Output_Pause_Status_CH1	Shows the status of 'Pulse_Output_Pause_CH1'
M00117	Pulse_Output_Pause_Status_CH2	Shows the status of 'Pulse_Output_Pause_CH2'
M00118	Pulse_Output_Pause_Status_CH3	Shows the status of 'Pulse_Output_Pause_CH3'
M00119	Pulse_Output_Pause_Status_CH4	Shows the status of 'Pulse_Output_Pause_CH4'
M00819	Frequency_Setting_error_flag_CH1	'TRUE' -Entered Start_end_freq frequency is out of range for channel 1. 'FALSE' - Entered Start_end_freq frequency is within range for channel 1.
M00835	Frequency_Setting_error_flag_CH2	'TRUE' -Entered Start_end_freq frequency is out of range for channel 2. 'FALSE' - Entered Start_end_freq frequency is within range for channel 2.
M00851	Frequency_Setting_error_flag_CH3	'TRUE' - Entered Start_end_freq frequency is out of range for channel 3. 'FALSE' - Entered Start_end_freq frequency is within range for channel 3.
M00859	Frequency_Setting_error_flag_CH4	'TRUE' -Entered Start_end_freq frequency is out of range for channel 4. 'FALSE' - Entered Start_end_freq frequency is within range for channel 4.
M00120	Auto_Reset_After_Pulse_Completed_CH1	if this is 'TRUE' then after enter number of pulses out Elapsed_Value_CH1 reset to zero and start pulse out again.
M00121	Auto_Reset_After_Pulse_Completed_CH2	if this is 'TRUE' then after enter number of pulses out Elapsed_Value_CH2 reset to zero and start pulse out again
M00122	Auto_Reset_After_Pulse_Completed_CH3	if this is 'TRUE' then after enter number of pulses out Elapsed_Value_CH3 reset to zero and start pulse out again.
M00123	Auto_Reset_After_Pulse_Completed_CH4	if this is 'TRUE' then after enter number of pulses out Elapsed_Value_CH4 reset to zero and start pulse out again.
M00124	Target_Frequency_Setting_Error_Flag_CH1	'TRUE' -Entered Pulse_op_Freq frequency is out of range for channel 1.

M00125	Target_Frequency_Setting_Error_Flag_CH 2	'TRUE' -Entered Pulse_op_Freq frequency is out of range for channel 2. 'FALSE'- Entered Pulse_op_Freq frequency is within range for channel 2.
M00126	Target_Frequency_Setting_Error_Flag_CH 3	'TRUE' -Entered Pulse_op_Freq frequency is out of range for channel 3. 'FALSE'- Entered Pulse_op_Freq frequency is within range for channel 3.
M00127	Target_Frequency_Setting_Error_Flag_CH 4	'TRUE' -Entered Pulse_op_Freq frequency is out of range for channel 4. 'FALSE'- Entered Pulse_op_Freq frequency is within range for channel 4.
M00822	No_of_Total_Pulses_Setting_error_flag_C H1	'TRUE' - Number of pulses enter out of range (0 to 4294967295) for channel 1. 'FALSE' - Number of pulses enter out of range (0 to 4294967295) for channel 1.
M00838	No_of_Total_Pulses_Setting_error_flag_C H2	'TRUE' - Number of pulses enter out of range (0 to 4294967295) for channel 2. 'FALSE' - Number of pulses enter out of range (0 to 4294967295) for channel 2.
M00854	No_of_Total_Pulses_Setting_error_flag_C H3	'TRUE' - Number of pulses enter out of range (0 to 4294967295) for channel 3. 'FALSE' - Number of pulses enter out of range (0 to 4294967295) for channel 3.
M00862	No_of_Total_Pulses_Setting_error_flag_C H4	'TRUE' - Number of pulses enter out of range (0 to 4294967295) for channel 4. 'FALSE' - Number of pulses enter out of range (0 to 4294967295) for channel 4.
M00823	End_of_Total_Pulses_Flag_CH1	'TRUE' - pulses out completed for channel 1. 'FALSE' - pulse out not completed for channel 1.
M00839	End_of_Total_Pulses_Flag_CH2	'TRUE' - pulses out completed for channel 2. 'FALSE' - pulse out not completed for channel 2.
M00855	End_of_Total_Pulses_Flag_CH3	'TRUE' - pulses out completed for channel 3. 'FALSE' - pulse out not completed for channel 3.
M00863	End_of_Total_Pulses_Flag_CH4	'TRUE' - pulses out completed for channel 4. 'FALSE' - pulse out not completed for channel 4.
M00820	Acceleration_Time_Setting_error_flag_CH1	'TRUE' - Entered Acceleration Time is out of range for channel 1. 'FALSE' - Entered Acceleration Time is within range for channel 1.
M00836	Acceleration_Time_Setting_error_flag_CH2	'TRUE' - Entered Acceleration Time is out of range for channel 2. 'FALSE' - Entered Acceleration Time is within range for channel 2.
M00852	Acceleration_Time_Setting_error_flag_CH3	'TRUE' - Entered Acceleration Time is out of range for channel 3 'FALSE' - Entered Acceleration Time is within range for channel 3.
M00860	Acceleration_Time_Setting_error_flag_CH4	'TRUE' - Entered Acceleration Time is out of range for channel 4. 'FALSE' - Entered Acceleration Time is within range for channel 4.

M00821	Deceleration_Time_Setting_error_flag_CH1	'TRUE' - Entered Deceleration Time is out of range for channel 1. 'FALSE' - Entered Deceleration Time is within range for channel 1..
M00837	Deceleration_Time_Setting_error_flag_CH2	'TRUE' - Entered Deceleration Time is out of range for channel 2. 'FALSE' - Entered Deceleration Time is within range for channel 2
M00853	Deceleration_Time_Setting_error_flag_CH3	'TRUE' - Entered Deceleration Time is out of range for channel 3. 'FALSE' - Entered Deceleration Time is within range for channel 3
M00861	Deceleration_Time_Setting_error_flag_CH4	'TRUE' - Entered Deceleration Time is out of range for channel 4. 'FALSE' - Entered Deceleration Time is within range for channel 4.
M00108	Decel_Condition_CH1	'TRUE'- after instruction deactivate, Pulse output is stopped with Decel for channel 1. 'FALSE'- after instruction deactivate, Pulse output is stopped immediately for channel 1.
M00109	Decel_Condition_CH2	'TRUE'- after instruction deactivate, Pulse output is stopped with Decel for channel 2. 'FALSE'- after instruction deactivate, Pulse output is stopped immediately for channel 2.
M00110	Decel_Condition_CH3	'TRUE'- after instruction deactivate, Pulse output is stopped with decel for channel 3. 'FALSE'- after instruction deactivate, Pulse output is stopped immediately for channel 3.
M00111	Decel_Condition_CH4	'TRUE'- after instruction deactivate, Pulse output is stopped with decel for channel 4. 'FALSE'- after instruction deactivate, Pulse output is stopped immediately for channel 4.
MW0068	Elapsed_Value_CH1	This tag shows current pulses out at channel 1. (Y0 : Pulses, Y1 : Direction)
MW0084	Elapsed_Value_CH2	This tag shows current pulses out at channel 2. (Y2 : Pulses, Y3 : Direction)
MW1709	Elapsed_Value_CH3	This tag shows current pulses out at channel 3. (Y4 : Pulses, Y5 : Direction)
MW1791	Elapsed_Value_CH4	This tag shows current pulses out at channel 4. (Y6 : Pulses, Y7 : Direction)
MW0054	Trapezoidal_Min_Pulse_Count_Register_C H1	Count shows in this tag is the minimum pulses required to generate trapezoidal profile according to other input parameters for channel 1.
MW0056	Trapezoidal_Min_Pulse_Count_Register_C H2	Count shows in this tag is the minimum pulses required to generate trapezoidal profile according to other input parameters for channel 2.
MW1711	Trapezoidal_Min_Pulse_Count_Register_C H3	Count shows in this tag is the minimum pulses required to generate trapezoidal profile according to other input parameters for channel 3.
MW1793	Trapezoidal_Min_Pulse_Count_Register_C H4	Count shows in this tag is the minimum pulses required to generate trapezoidal profile according to other input parameters for channel 4.

M00140	Decel_Condition_Completed_CH1	When Decel_Condition_CH1 is TRUE and if instruction completed with deceleration then this flag is set.
M00141	Decel_Condition_Completed_CH2	When Decel_Condition_CH2 is TRUE and if instruction completed with deceleration then this flag is set.
M00142	Decel_Condition_Completed_CH3	When Decel_Condition_CH3 is TRUE and if instruction completed with deceleration then this flag is set.
M00143	Decel_Condition_Completed_CH4	When Decel_Condition_CH4 is TRUE and if instruction completed with deceleration then this flag is set.

3. Pulse Output

Function

This instruction works in Pulse + Direction mode.

When Enable Input is ON, This Instruction Out Pulses on Selected High Speed Output Channel at entered Frequency & Duty Cycle.

Direction output Status is depends on Sign of entered Frequency and PulseOp_Dir_CoOrdinate_Change_CHx Bit.

If Nounber of Pulses is '0' then it outs unlimited Pulses, Otherwise it out Pulses as per Entered Value.

Execution Condition

Condition	Action
The rung-condition-in is false	The rung-condition-out is false
The rung-condition-in is true	The rung-condition-out is set to true only if Enable is true

Operands

Operands	Type	Descriptions
Enable	BOOL	BOOL Value. Enable or Disable instruction.
Channel_No	USINT	Enter Channel number e.g. Enter '1' for CH-1(Y0-Pulses, Y1-Dir) .
Frequency	DINT	Range of Frequency is depending on Product. If Entered freq is more/less than Specified freq then Freq_Setting_Error_Flag will be Set and Instruction will work at limiting frequency of that product.
Duty_Cycle	UDINT	Range : 1% to 99%, if Entered Value is autof of this Range then ON_duty_setting_error_flag will be Set and instruction will work at 50 % duty cycle.
NoOfPulses	DINT	Specified as '0' : pulse will be output continuously regardless of the limit of pulse number.
CH_Error	BOOL	If Entered Channel_No is more/less than the Pulse_Dir channels that product have , then CH_Error is Set.

Example

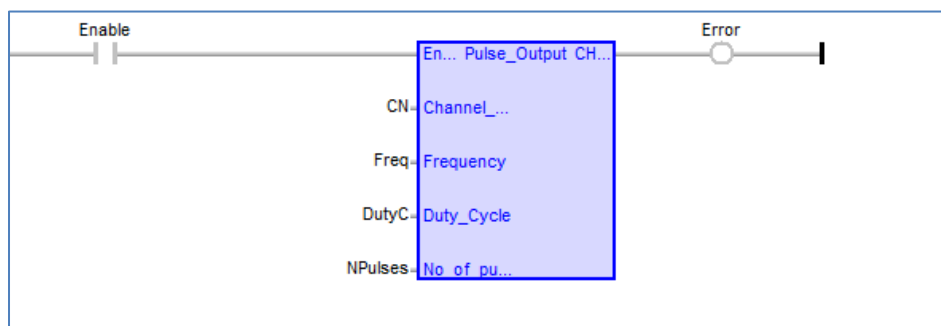

if Enable is ON, Pulse Output Instruction will be Executed.

if CN = 1, Freq = 1000, DutyC = 50 & No_of_Pulses = 10000 then total 10000 Pulses will be outputs on Channel '1' Y0. & Y1 is Off.

if CN = 1, Freq = -1000, DutyC = 50 & No_of_Pulses = 10000 then total 10000 Pulses will be outputs on Channel '1' Y0. & Y1 is ON.

if No_of_pulses = 0 then pulses will be outputs continuously regardless of limit.

if CN is more/less than the Pulse_Output channels that product have then Error is ON.

Associated Special Tags/Bits

Tags/Bits	Tag/Bit Name	Description
M00104	PulseOp_Dir_CoOrdinate_Change_CH1	When this bit is Set, Reverse the direction conditions of direction output Y1. if 'FALSE': +ve Freq, Y1-OFF & -ve Freq, Y1-ON. if 'TRUE': +ve Freq, Y1-ON & -ve Freq, Y1-OFF.
M00105	PulseOp_Dir_CoOrdinate_Change_CH2	When this bit is Set, Reverse the direction conditions of direction output Y3. if 'FALSE': +ve Freq, Y3-OFF & -ve Freq, Y3-ON if 'TRUE': +ve Freq, Y3-ON & -ve Freq, Y3-OFF
M00106	PulseOp_Dir_CoOrdinate_Change_CH3	When this bit is Set, Reverse the direction conditions of direction output Y5. if 'FALSE': +ve Freq, Y5-OFF & -ve Freq, Y5-ON if 'TRUE': +ve Freq, Y5-ON & -ve Freq, Y5-OFF
M00107	PulseOp_Dir_CoOrdinate_Change_CH4	When this bit is Set, Reverse the direction conditions of direction output Y7. if 'FALSE': +ve Freq, Y7-OFF & -ve Freq, Y7-ON if 'TRUE': +ve Freq, Y7-ON & -ve Freq, Y7-OFF
M00112	Pulse_Output_Pause_CH1	If This Bit is 'TRUE' - Stop Pulses immediately of channel 1 - Y0. 'FALSE' - Resume and starts Pulse out at Y0.
M00113	Pulse_Output_Pause_CH2	If This Bit is 'TRUE' - Stop Pulses immediately of channel 2 - Y2. 'FALSE' - Resume and starts Pulse out at Y2.
M00114	Pulse_Output_Pause_CH3	If This Bit is 'TRUE' - Stop Pulses immediately of channel 3 - Y4. 'FALSE' - Resume and starts Pulse out at Y4.
M00115	Pulse_Output_Pause_CH4	If This Bit is 'TRUE' - Stop Pulses immediately of channel 4 - Y6. 'FALSE' - Resume and starts Pulse out at Y6.
M00116	Pulse_Output_Pause_Status_CH1	Shows the status of 'Pulse_Output_Pause_CH1'.
M00117	Pulse_Output_Pause_Status_CH2	Shows the status of 'Pulse_Output_Pause_CH2'.
M00118	Pulse_Output_Pause_Status_CH3	Shows the status of 'Pulse_Output_Pause_CH3'.
M00119	Pulse_Output_Pause_Status_CH4	Shows the status of 'Pulse_Output_Pause_CH4'.
M00819	Frequency_Setting_error_flag_CH1	'TRUE' -Entered frequency is out of range for channel 1. 'FALSE'- Entered frequency is within range for channel 1.
M00835	Frequency_Setting_error_flag_CH2	'TRUE' -Entered frequency is out of range for channel 2.

		'FALSE'- Entered frequency is within range for channel 2.
M00851	Frequency_Setting_error_flag_CH3	'TRUE' -Entered frequency is out of range for channel 3. 'FALSE'- Entered frequency is within range for channel 3.
M00859	Frequency_Setting_error_flag_CH4	'TRUE' -Entered frequency is out of range for channel 4. 'FALSE'- Entered frequency is within range for channel 4.
M00120	Auto_Reset_After_Pulse_Completed_CH1	if this is 'TRUE' then after enter number of pulses out. Elapsed_Value_CH1 reset to zero and start pulse out again.
M00121	Auto_Reset_After_Pulse_Completed_CH2	if this is 'TRUE' then after enter number of pulses out. Elapsed_Value_CH2 reset to zero and start pulse out again.
M00122	Auto_Reset_After_Pulse_Completed_CH3	if this is 'TRUE' then after enter number of pulses out. Elapsed_Value_CH3 reset to zero and start pulse out again
M00123	Auto_Reset_After_Pulse_Completed_CH4	if this is 'TRUE' then after enter number of pulses out. Elapsed_Value_CH4 reset to zero and start pulse out again
M00818	ON_duty_setting_error_flag_CH1	'TRUE' - Entered Duty Cycle is out of range (1 % to 99 %) for channel 1. 'FALSE' - Entered Duty Cycle is within range (1 % to 99 %) for channel 1.
M00834	ON_duty_setting_error_flag_CH2	'TRUE' - Entered Duty Cycle is out of range (1 % to 99 %) for channel 2. 'FALSE' - Entered Duty Cycle is within range (1 % to 99 %) for channel 2.
M00850	ON_duty_setting_error_flag_CH3	'TRUE' - Entered Duty Cycle is out of range (1 % to 99 %) for channel 3. 'FALSE' - Entered Duty Cycle is within range (1 % to 99 %) for channel 3.
M00858	ON_duty_setting_error_flag_CH4	'TRUE' - Entered Duty Cycle is out of range (1 % to 99 %) for channel 4. 'FALSE' - Entered Duty Cycle is within range (1 % to 99 %) for channel 4.
M00822	No_of_Total_Pulses_Setting_error_flag_C H1	'TRUE' - Number of pulses enter out of range (0 to 4294967295) for channel 1. 'FALSE' - Number of pulses enter out of range (0 to 4294967295) for channel 1.
M00838	No_of_Total_Pulses_Setting_error_flag_C H2	'TRUE' - Number of pulses enter out of range (0 to 4294967295) for channel 2. 'FALSE' - Number of pulses enter out of range (0 to 4294967295) for channel 2.
M00854	No_of_Total_Pulses_Setting_error_flag_C H3	'TRUE' - Number of pulses enter out of range (0 to 4294967295) for channel 3. 'FALSE' - Number of pulses enter out of range (0 to 4294967295) for channel 3.
M00862	No_of_Total_Pulses_Setting_error_flag_C H4	'TRUE' - Number of pulses enter out of range (0 to 4294967295) for channel 4.

		'FALSE' - Number of pulses enter out of range (0 to 4294967295) for channel 4.
M00823	End_of_Total_Pulses_Flag_CH1	'TRUE' - pulses out completed for channel 1. 'FALSE' - pulse out not completed for channel 1.
M00839	End_of_Total_Pulses_Flag_CH2	'TRUE' - pulses out completed for channel 2. 'FALSE' - pulse out not completed for channel 2.
M00855	End_of_Total_Pulses_Flag_CH3	'TRUE' - pulses out completed for channel 3. 'FALSE' - pulse out not completed for channel 3.
M00863	End_of_Total_Pulses_Flag_CH4	'TRUE' - pulses out completed for channel 4. 'FALSE' - pulse out not completed for channel 4.
MW0068	Elapsed_Value_CH1	This tag shows current pulses out at channel 1. (Y0 : Pulses, Y1 : Direction) if Freq is +ve: tag shows incrementing pulse count. Freq is -ve : tag shows decrementing pulse count.
MW0084	Elapsed_Value_CH2	This tag shows current pulses out at channel 1. (Y2 : Pulses, Y3 : Direction) if Freq is +ve: tag shows incrementing pulse count. Freq is -ve : tag shows decrementing pulse count.
MW1709	Elapsed_Value_CH3	This tag shows current pulses out at channel 1. (Y4 : Pulses, Y5 : Direction) if Freq is +ve: tag shows incrementing pulse count. Freq is -ve : tag shows decrementing pulse count.
MW1791	Elapsed_Value_CH4	This tag shows current pulses out at channel 1. (Y6: Pulses, Y7: Direction) if Freq is +ve: tag shows incrementing pulse count. Freq is -ve : tag shows decrementing pulse count.

4. Zero Return

Function

This instruction used for home detection (Zero Return Point). Instruction can be used with Abs_Pos_Control and Rel_Pos_Control in position control applications.

Executive Condition

Condition	Action
The rung-condition-in is false	The rung-condition-out is false
The rung-condition-in is true	The rung-condition-out is set to true only if Enable is true

Operands

Operands	Type	Descriptions
Enable	BOOL	BOOL Value Enable or Disable instruction
Start_Freq	UDINT	Start Frequency of Zero return instruction. Sero starts accelerating from Start_Freq. If Entered freq is more/less than Specified freq then Freq_Setting_Error_Flag will be Set and Instruction will work at lower/upper bound of freq as Start_End_Freq. (unit : Hz)
Zero_Return_Speed	UDINT	Creep Speed If Entered freq is more/less than Specified freq then Creep_Freq_Error_Flag_CH will be Set and Instruction will work at lower/upper bound of freq as Creep_Speed Frequency. (Unit : Hz)
Creep_Speed	UDINT	If Entered freq is more/less than Specified freq then Creep_Freq_Error_Flag_CH will be Set and Instruction will work at lower/upper bound of freq as Creep_Speed Frequency.(Unit : Hz)
Acc_Time_mS	UINT	Acceleration Time in mSec. If Entered time is more/less than specified range, then Acceleration_Time_Setting_error_flag will be set and instruction will work at lower/upper bound of Acceleration Time. For FL004-Series : unit is 1mSec :: FL005 & FL055 Series : unit is 10mSec.
Dec_Time_mS	UINT	Deceleration Time in mSec. If Entered time is more/less than specified range, then Deceleration_Time_Setting_error_flag will be set and instruction will work at lower/upper bound of Deceleration Time. For FL004-Series : unit is 1mSec :: FL005 & FL055 Series : unit is 10mSec.
CH_Error	BOOL	If Entered Channel_No is more/less than the Pulse_Dir channels that product have , then CH_Error is Set.
X	USINT	DOG Input point (Please refer table section).
Y	USINT	Pulse output device (Please refer table section).
Error	BOOL	Set If combination of X & Y is not as per the table in 8DI_8DO Models & 16DI_16DO Models.

How to enter value to select X & Y ?

if you want to select Y0 & X2 Combination then provide value 2 for X & 0 for Y inputs of instructions.

Example

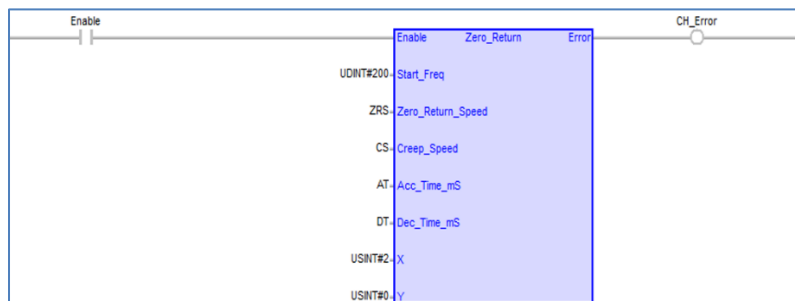

Where,

Enable : Activate the instruction

Start_Freq : Start Frequency

ZRS : Zero Return Speed / Target Freq

CS : Creep Speed/Start Freq

AT : Acceleration Time in mS

DT : Deceleration Time in mS

X : Near Point Signal DOG

Y : Pulse Output Device

Error : Set If combination of X & Y is not as per the table in 8DI_8_6DO Models & 16DI_16DO Models sheets.

Table

FL004-0806P/N		
	CH-1	CH-2
Output Point Number(Y)	Y0	Y2
Corresponding output point number(Dir)	Y1	Y3
DOG point number(X)	X2	X6
Left Limit Switch_CHx	M00136	M00137
Left limit input point	X3	X7
The Left limit switch is triggered by the rising- edge signal. (OFF: Rising Edge Signal; ON: Falling edge signal)	M00146	M00147
Searching for the Zphase	Z Phase number	Positive value: Searching for the Z phase in positive direction.
	The number of times the Z phase is searched for is stored in MW1795.	Negative Value: searching for the Z phase in negative direction.
Number of displacements	The number of displacements is stored in MW1795.	Positive value: The pulse output in positive direction. Negative Value: The pulse output in negative direction.
Clearing the Output (M00145=On)	Y4	Y5
M00150	Execution_Complete_CH1(Y0)	
M00151	Execution_Complete_CH2(Y2)	

Associated Special Tags/Bits

Tags/Bits	Tag/Bit Name	Descriptions
M00104	PulseOp_Dir_CoOrdinate_Change_CH1	When this bit is Set, Reverse the direction conditions of direction output Y1. if 'FALSE' : NoOfPulses is +ve, Y1-OFF & NoOfPulses is -ve , Y1-ON if 'TRUE' : NoOfPulses is +ve, Y1-ON & NoOfPulses is -ve , Y1-OFF
M00105	PulseOp_Dir_CoOrdinate_Change_CH2	When this bit is Set, Reverse the direction conditions of direction output Y3. if 'FALSE': NoOfPulses is +ve, Y3-OFF & NoOfPulses is -ve, Y3-ON. if 'TRUE' : NoOfPulses is +ve, Y3-ON & NoOfPulses is -ve , Y3-OFF.
M00106	PulseOp_Dir_CoOrdinate_Change_CH3	When this bit is Set, Reverse the direction conditions of direction output Y5. if 'FALSE': NoOfPulses is +ve, Y5-OFF & NoOfPulses is -ve, Y5-ON. if 'TRUE' : NoOfPulses is +ve, Y5-ON & NoOfPulses is -ve , Y5-OFF.
M00107	PulseOp_Dir_CoOrdinate_Change_CH4	When this bit is Set, Reverse the direction conditions of direction output Y7. if 'FALSE': NoOfPulses is +ve, Y7-OFF & NoOfPulses is -ve, Y7-ON. if 'TRUE' : NoOfPulses is +ve, Y7-ON & NoOfPulses is -ve , Y7-OFF.
M00112	Pulse_Output_Pause_CH1	If This Bit is 'TRUE' - Stop Pulses immediately of channel 1 - Y0. 'FALSE' - Resume and starts Pulse out at Y0.
M00113	Pulse_Output_Pause_CH2	If This Bit is 'TRUE' - Stop Pulses immediately of channel 2 - Y2. 'FALSE' - Resume and starts Pulse out at Y2.
M00114	Pulse_Output_Pause_CH3	If This Bit is 'TRUE' - Stop Pulses immediately of channel 3 - Y4. 'FALSE' - Resume and starts Pulse out at Y4.
M00115	Pulse_Output_Pause_CH4	If This Bit is 'TRUE' - Stop Pulses immediately of channel 4 - Y6. 'FALSE' - Resume and starts Pulse out at Y6.
M00116	Pulse_Output_Pause_Status_CH1	Shows the status of ' Pulse_Output_Pause_CH1'.
M00117	Pulse_Output_Pause_Status_CH2	Shows the status of ' Pulse_Output_Pause_CH2'.
M00118	Pulse_Output_Pause_Status_CH3	Shows the status of ' Pulse_Output_Pause_CH3'.
M00119	Pulse_Output_Pause_Status_CH4	Shows the status of ' Pulse_Output_Pause_CH4'.
M00819	Frequency_Setting_error_flag_CH1	'TRUE' -Entered Start_freq frequency is out of range for channel 1. 'FALSE'- Entered Start_freq frequency is within range for channel 1.
M00835	Frequency_Setting_error_flag_CH2	'TRUE' -Entered Start_freq frequency is out of range for channel 2. 'FALSE'- Entered Start_freq frequency is within range for channel 2.

M00851	Frequency_Setting_error_flag_CH3	'TRUE' -Entered Start_freq frequency is out of range for channel 3. 'FALSE'- Entered Start_freq frequency is within range for channel 3..
M00859	Frequency_Setting_error_flag_CH4	'TRUE' -Entered Start_freq frequency is out of range for channel. 'FALSE'- Entered Start_freq frequency is within range for channel 4.
M00120	Auto_Reset_After_Pulse_Completed_CH1	if this is 'TRUE' then after enter number of pulses out. Elapsed_Value_CH1 reset to zero and start pulse out again.
M00121	Auto_Reset_After_Pulse_Completed_CH2	if this is 'TRUE' then after enter number of pulses out. Elapsed_Value_CH2 reset to zero and start pulse out again.
M00122	Auto_Reset_After_Pulse_Completed_CH3	if this is 'TRUE' then after enter number of pulses out. Elapsed_Value_CH3 reset to zero and start pulse out again.
M00123	Auto_Reset_After_Pulse_Completed_CH4	if this is 'TRUE' then after enter number of pulses out. Elapsed_Value_CH4 reset to zero and start pulse out again.
M00124	Target_Frequency_Setting_Error_Flag_CH1	'TRUE' -Entered Zero_Return_Speed frequency is out of range for channel 1. 'FALSE'- Entered Zero_Return_Speed frequency is within range for channel 1.
M00125	Target_Frequency_Setting_Error_Flag_CH2	'TRUE' -Entered Zero_Return_Speed frequency is out of range for channel 2. 'FALSE'- Entered Zero_Return_Speed frequency is within range for channel 2.
M00126	Target_Frequency_Setting_Error_Flag_CH3	'TRUE' -Entered Zero_Return_Speed frequency is out of range for channel 3. 'FALSE'- Entered Zero_Return_Speed frequency is within range for channel 3.
M00127	Target_Frequency_Setting_Error_Flag_CH4	'TRUE' -Entered Zero_Return_Speed frequency is out of range for channel 4. 'FALSE'- Entered Zero_Return_Speed frequency is within range for channel 4.
M00820	Acceleration_Time_Setting_error_flag_CH1	'TRUE' - Entered Acceleration Time is out of range for channel 1. 'FALSE' - Entered Acceleration Time is within range for channel 1.
M00836	Acceleration_Time_Setting_error_flag_CH2	'TRUE' - Entered Acceleration Time is out of range for channel 2. 'FALSE' - Entered Acceleration Time is within range for channel 2..
M00852	Acceleration_Time_Setting_error_flag_CH3	'TRUE' - Entered Acceleration Time is out of range for channel 3. 'FALSE' - Entered Acceleration Time is within range for channel 3.
M00860	Acceleration_Time_Setting_error_flag_CH4	'TRUE' - Entered Acceleration Time is out of range for channel 4. 'FALSE' - Entered Acceleration Time is within range for channel 4.

M00821	Deceleration_Time_Setting_error_flag_CH1	'TRUE' - Entered Deceleration Time is out of range for channel 1. 'FALSE' - Entered Deceleration Time is within range for channel 1.
M00837	Deceleration_Time_Setting_error_flag_CH2	'TRUE' - Entered Deceleration Time is out of range for channel 2. 'FALSE' - Entered Deceleration Time is within range for channel 2.
M00853	Deceleration_Time_Setting_error_flag_CH3	'TRUE' - Entered Deceleration Time is out of range for channel 3. 'FALSE' - Entered Deceleration Time is within range for channel 3.
M00861	Deceleration_Time_Setting_error_flag_CH4	'TRUE' - Entered Deceleration Time is out of range for channel 4. 'FALSE' - Entered Deceleration Time is within range for channel 4.
M00108	Decel_Condition_CH1	'TRUE'- after instruction deactivate, Pulse output is stopped with decel for channel 1. 'FALSE'- after instruction deactivate, Pulse output is stopped immediately for channel 1.
M00109	Decel_Condition_CH2	'TRUE'- after instruction deactivate, Pulse output is stopped with decel for channel 2. 'FALSE'- after instruction deactivate, Pulse output is stopped immediately for channel 2.
M00110	Decel_Condition_CH3	'TRUE'- after instruction deactivate, Pulse output is stopped with decel for channel 3. 'FALSE'- after instruction deactivate, Pulse output is stopped immediately for channel 3.
M00111	Decel_Condition_CH4	'TRUE'- after instruction deactivate, Pulse output is stopped with decel for channel 4. 'FALSE'- after instruction deactivate, Pulse output is stopped immediately for channel 4.
MW0068	Elapsed_Value_CH1	This tag shows current pulses out at channel 1. (Y0 : Pulses, Y1 : Direction)
MW0084	Elapsed_Value_CH2	This tag shows current pulses out at channel 2. (Y2 : Pulses, Y3 : Direction)
MW1709	Elapsed_Value_CH3	This tag shows current pulses out at channel 3. (Y4 : Pulses, Y5 : Direction)
MW1791	Elapsed_Value_CH4	This tag shows current pulses out at channel 4. (Y6 : Pulses, Y7 : Direction)
M00136	Left_Limit_Switch_CH1	This bit is used to enable/disable the left limit switch for CH1. TRUE - Enable, FALSE – Disable This bit should be set up before instruction execution
M00137	Left_Limit_Switch_CH2	This bit is used to enable/disable the left limit switch for CH2. TRUE - Enable, FALSE – Disable This bit should be set up before instruction execution.
M00138	Left_Limit_Switch_CH3	This bit is used to enable/disable the left limit switch for CH3.

		TRUE - Enable, FALSE – Disable This bit should be set up before instruction execution.
M00139	Left_Limit_Switch_CH4	This bit is used to enable/disable the left limit switch for CH4. TRUE - Enable, FALSE – Disable This bit should be set up before instruction execution.
M00140	Decel_Condition_Completed_CH1	When Decel_Condition_CH1 is TRUE and if instruction completed with deceleration then this flag is set
M00141	Decel_Condition_Completed_CH2	When Decel_Condition_CH2 is TRUE and if instruction completed with deceleration then this flag is set.
M00142	Decel_Condition_Completed_CH3	When Decel_Condition_CH3 is TRUE and if instruction completed with deceleration then this flag is set.
M00143	Decel_Condition_Completed_CH4	When Decel_Condition_CH4 is TRUE and if instruction completed with deceleration then this flag is set.
M00144	Z-Phase_Search	This bit is used to select Z-phase signal on Z phase input point or Displacement. TRUE – Displacement FALSE - Z-Phase Search
M00145	DZRN_Clearing_Output	this bit is used to enable or Disable clearing output after execution completed. TRUE – Enable FALSE - Disable
M00146	Left_Limit_Switch_EgdeSel_CH1	The left limit switch is triggered by a rising-edge signal or a falling-edge signal for CH1. FALSE: Rising-edge signal; TRUE: Falling-edge signal
M00147	Left_Limit_Switch_EgdeSel_CH2	The left limit switch is triggered by a rising-edge signal or a falling-edge signal for CH2. FALSE: Rising-edge signal; TRUE: Falling-edge signal
M00148	Left_Limit_Switch_EgdeSel_CH3	The left limit switch is triggered by a rising-edge signal or a falling-edge signal for CH3. FALSE: Rising-edge signal; TRUE: Falling-edge signal
M00149	Left_Limit_Switch_EgdeSel_CH4	The left limit switch is triggered by a rising-edge signal or a falling-edge signal for CH4. FALSE: Rising-edge signal; TRUE: Falling-edge signal
M00150	Execution_Complete_CH1	This bit is set after DZRN execution completed for CH1.
M00151	Execution_Complete_CH2	This bit is set after DZRN execution completed for CH2.
M00152	Execution_Complete_CH3	This bit is set after DZRN execution completed for CH3.
M00153	Execution_Complete_CH4	This bit is set after DZRN execution completed for CH4.

M00154	Creep_Freq_Error_Flag_CH1	'TRUE' -Entered Creep_Speed frequency is out of range for channel 1. 'FALSE'- Entered Creep_Speed frequency is within range for channel 1.
M00155	Creep_Freq_Error_Flag_CH2	'TRUE' -Entered Creep_Speed frequency is out of range for channel 2. 'FALSE'- Entered Creep_Speed frequency is within range for channel 2.
M00156	Creep_Freq_Error_Flag_CH3	'TRUE' -Entered Creep_Speed frequency is out of range for channel 3. 'FALSE'- Entered Creep_Speed frequency is within range for channel 3.
M00157	Creep_Freq_Error_Flag_CH4	'TRUE' -Entered Creep_Speed frequency is out of range for channel 4. 'FALSE'- Entered Creep_Speed frequency is within range for channel 4.
MW1795	DZRN_Z_Phase_Or_Displacement	The number of times the Z phase/Displacement is searched for is stored in MW1795. Positive value: Searching for the Z phase/Displacement in the positive direction. Negative value: Searching for the Z phase/Displacement in the negative direction.

Timing Diagram

State1:

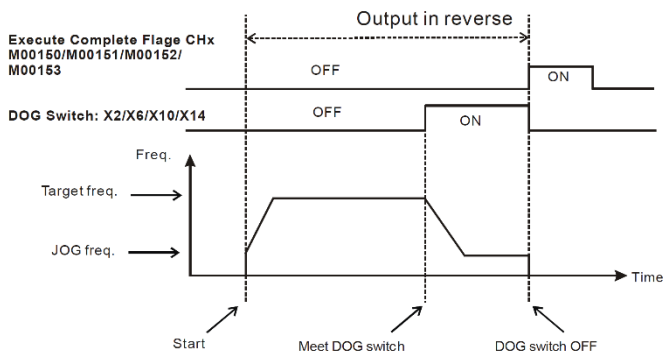

DOG Switch is OFF
 Left_Limit_Switch_CHx = FALSE
 DZRN_Clearing_Output= FALSE

State2:

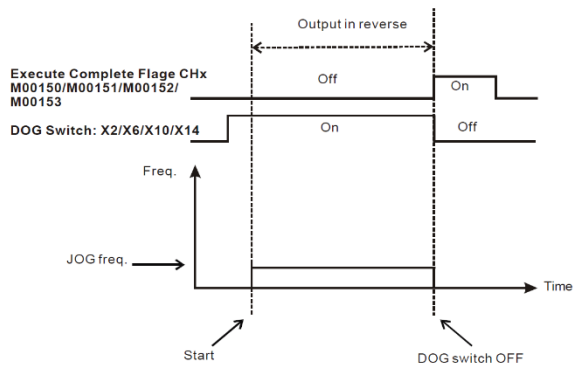

DOG Switch is ON
 Left_Limit_Switch_CHx = FALSE
 DZRN_Clearing_Output= FALSE

State3:

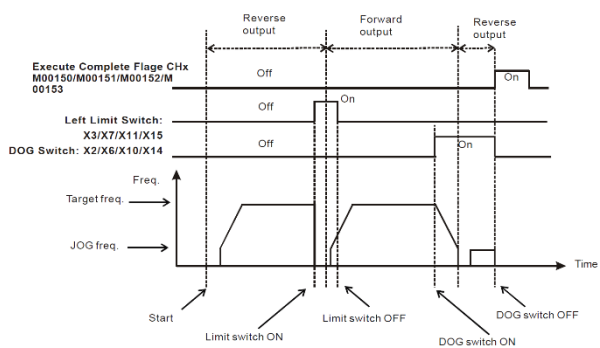

DOG Switch is OFF
 Left_Limit_Switch_CHx = TRUE
 DZRN_Clearing_Output= FALSE

State4:

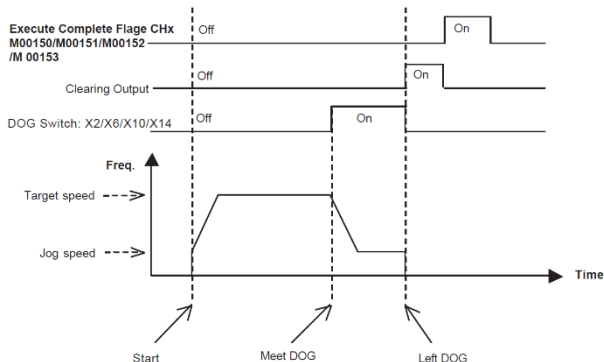

DOG Switch is OFF
 Left_Limit_Switch_CHx = FALSE
 DZRN_Clearing_Output= TRUE

State5:

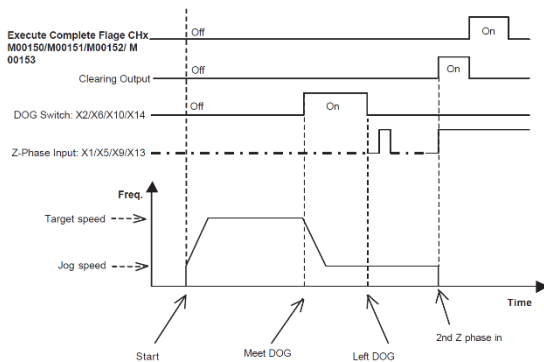

DOG Switch is OFF
 DZRN_Z_Phase_or_Displacement=-2
 Z_Phase_Search=FALSE
 DZRN_Clearing_Output= TRUE

State6:

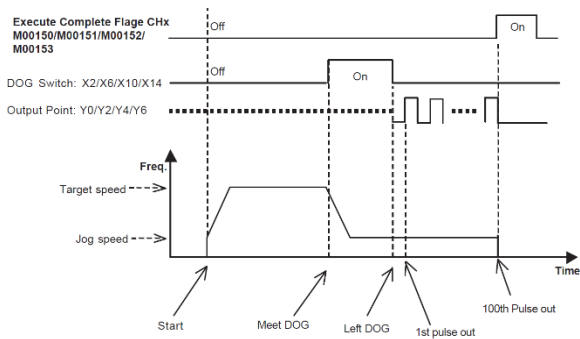

DOG Switch is OFF
 DZRN_Z_Phase_or_Displacement=-100
 Z_Phase_Search= TRUE
 DZRN_Clearing_Output= FALSE

5. Absolute Position Control

Function

The instruction only supports the pulse output type: Pulse + Direction.

NoOfPulses is the target position for absolute positioning. The actual number of output pulses will be calculated by PLC. When the result is positive, pulse output executes forward operation, i.e. Dir = OFF; when the results is negative, pulse output executes reverse operation, i.e. Dir = ON.

The set value in NoOfPulses is the absolute position from zero point. The calculated actual number of output pulses will be the relative position of Current Position which is stored in Elapsed Value Register.

Executive Condition

Condition	Action
The rung-condition-in is false	The rung-condition-out is false
The rung-condition-in is true	The rung-condition-out is set to true only if Enable is true

Operands

Operands	Type	Descriptions
Enable	BOOL	BOOL Value Enable or Disable instruction.
Channel_No	USINT	Enter Channel number e.g. Enter '1' for CH-1(Y0-Pulses, Y1-Dir)
Start_End_Freq	UDINT	Start_End_Freq of Pulse Output i.e. Min Freq. If Entered freq is more/less than Specified freq then Freq_Setting_Error_Flag will be Set and Instruction will work at lower/upper bound of freq as Start_End_Freq.
Pulse_Op_Freq	UDINT	Pulse Output Frequency i.e. Max Freq. If Entered freq is more/less than Specified freq then Target_Frequency_Setting_Error_Flag will be Set and Instruction will work at lower/upper bound of freq as Pulse_Op_Freq.
Acc_Time_mS	UINT	Acceleration Time in mSec. If Entered time is more/less than specified range, then Acceleration_Time_Setting_error_flag will be set and instruction will work at lower/upper bound of Acceleration Time. For FL004-Series : unit is 1mSec :: FL005 & FL055 Series : unit is 10mSec.
Dec_Time_mS	UINT	Deceleration Time in mSec. If Entered time is more/less than specified range, then Deceleration_Time_Setting_error_flag will be set and instruction will work at lower/upper bound of Deceleration Time. For FL004-Series : unit is 1mSec :: FL005 & FL055 Series : unit is 10mSec.
NoOfPulses	DINT	Number of Pulses.
CH_Error	BOOL	If Entered Channel_No is more/less than the Pulse_Ramp channels that product have , then CH_Error is Set.

Example

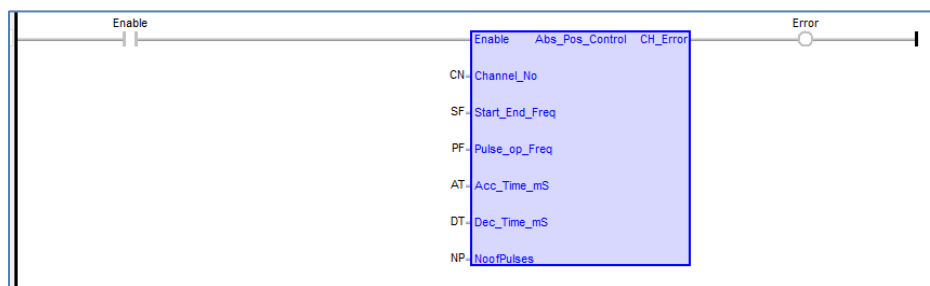

If CN = 1, Enable is ON & Configured Specified Input Parameters then Pulses will be outputted with Trapezoidal Profile on Selected Channels.

Channel_Num, Start_End_Freq, Pulse_Op_Freq, Acc_Time_mS, Dec_Time_mS & NoOfPulses are Entered then trapezoidal Profile will generate.

Trapezoidal_Min_Pulse_Count_Register_CHx shows the minimum pulses required to generate trapezoidal profile.

Trapezoidal_Min_Pulse_Count is calculated by using Start_End_Freq, Pulse_Op_Freq, Acc_Time_mS, Dec_Time_mS by PLC internally and shows count in Trapezoidal_Min_Pulse_Count_Register_CHx tag.

The actual number of output pulses will be calculated by PLC. When the result is positive, pulse output executes forward operation, i.e. Dir = OFF;

when the results is negative, pulse output executes reverse operation, i.e. Dir = ON.

Associated Special Tags/Bits

Tags/Bits	Tag/Bit Name	Descriptions
M00104	PulseOp_Dir_CoOrdinate_Change_CH1	When this bit is Set, Reverse the direction conditions of direction output Y1. if 'FALSE': Calculated actual pulses result is +ve, Y1-OFF & result is -ve, Y1-ON. if 'TRUE' : Calculated actual pulses result is +ve, Y1-ON & result is -ve, Y1-OFF.
M00105	PulseOp_Dir_CoOrdinate_Change_CH2	When this bit is Set, Reverse the direction conditions of direction output Y3. if 'FALSE': Calculated actual pulses result is +ve, Y3-OFF & result is -ve, Y3-ON. if 'TRUE' : Calculated actual pulses result is +ve, Y3-ON & result is -ve, Y3-OFF.
M00106	PulseOp_Dir_CoOrdinate_Change_CH3	When this bit is Set, Reverse the direction conditions of direction output Y5. if 'FALSE': Calculated actual pulses result is +ve, Y5-OFF & result is -ve, Y5-ON. if 'TRUE' : Calculated actual pulses result is +ve, Y5-ON & result is -ve, Y5-OFF.
M00107	PulseOp_Dir_CoOrdinate_Change_CH4	When this bit is Set, Reverse the direction conditions of direction output Y7. if 'FALSE': Calculated actual pulses result is +ve, Y7-OFF & result is -ve, Y7-ON. if 'TRUE' : Calculated actual pulses result is +ve, Y7-ON & result is -ve, Y7-OFF.

M00112	Pulse_Output_Pause_CH1	If This Bit is 'TRUE' - Stop Pulses immediately of channel 1 - Y0.'FALSE' - Resume and starts Pulse out at Y0.
M00113	Pulse_Output_Pause_CH2	If This Bit is 'TRUE' - Stop Pulses immediately of channel 2 - Y2. 'FALSE' - Resume and starts Pulse out at Y2.
M00114	Pulse_Output_Pause_CH3	If This Bit is 'TRUE' - Stop Pulses immediately of channel 3 - Y4. 'FALSE' - Resume and starts Pulse out at Y4.
M00115	Pulse_Output_Pause_CH4	If This Bit is 'TRUE' - Stop Pulses immediately of channel 4 - Y6. 'FALSE' - Resume and starts Pulse out at Y6.
M00116	Pulse_Output_Pause_Status_CH1	Shows the status of 'Pulse_Output_Pause_CH1'.
M00117	Pulse_Output_Pause_Status_CH2	Shows the status of 'Pulse_Output_Pause_CH2'.
M00118	Pulse_Output_Pause_Status_CH3	Shows the status of 'Pulse_Output_Pause_CH3'.
M00119	Pulse_Output_Pause_Status_CH4	Shows the status of 'Pulse_Output_Pause_CH4'.
M00819	Frequency_Setting_error_flag_CH1	'TRUE' -Entered Start_end_freq frequency is out of range for channel 1. 'FALSE'- Entered Start_end_freq frequency is within range for channel 1.
M00835	Frequency_Setting_error_flag_CH2	'TRUE' -Entered Start_end_freq frequency is out of range for channel 2. 'FALSE'- Entered Start_end_freq frequency is within range for channel 2.
M00851	Frequency_Setting_error_flag_CH3	'TRUE' -Entered Start_end_freq frequency is out of range for channel 3. 'FALSE'- Entered Start_end_freq frequency is within range for channel 3.
M00859	Frequency_Setting_error_flag_CH4	'TRUE' -Entered Start_end_freq frequency is out of range for channel 4. 'FALSE'- Entered Start_end_freq frequency is within range for channel 4.
M00120	Auto_Reset_After_Pulse_Completed_CH1	if this is 'TRUE' then after enter number of pulses out. Elapsed_Value_CH1 reset to zero and start pulse out again.
M00121	Auto_Reset_After_Pulse_Completed_CH2	if this is 'TRUE' then after enter number of pulses out. Elapsed_Value_CH2 reset to zero and start pulse out again.
M00122	Auto_Reset_After_Pulse_Completed_CH3	if this is 'TRUE' then after enter number of pulses out. Elapsed_Value_CH3 reset to zero and start pulse out again.
M00123	Auto_Reset_After_Pulse_Completed_CH4	if this is 'TRUE' then after enter number of pulses out. Elapsed_Value_CH4 reset to zero and start pulse out again.
M00124	Target_Frequency_Setting_Error_Flag_CH1	'TRUE' -Entered Pulse_op_Freq frequency is out of range for channel 1.. 'FALSE'- Entered Pulse_op_Freq frequency is within range for channel 1.

M00125	Target_Frequency_Setting_Error_Flag_CH2	'TRUE' -Entered Pulse_op_Freq frequency is out of range for channel 2. 'FALSE'- Entered Pulse_op_Freq frequency is within range for channel 2.
M00126	Target_Frequency_Setting_Error_Flag_CH3	'TRUE' - Entered Pulse_op_Freq frequency is out of range for channel 3. 'FALSE'- Entered Pulse_op_Freq frequency is within range for channel 3.
M00127	Target_Frequency_Setting_Error_Flag_CH4	'TRUE' -Entered Pulse_op_Freq frequency is out of range for channel 4. 'FALSE'- Entered Pulse_op_Freq frequency is within range for channel 4.
M00822	No_of_Total_Pulses_Setting_error_flag_CH1	'TRUE' - Number of pulses enter out of range (0 to 4294967295) for channel 1. 'FALSE' - Number of pulses enter out of range (0 to 4294967295) for channel 1.
M00838	No_of_Total_Pulses_Setting_error_flag_CH2	'TRUE' - Number of pulses enter out of range (0 to 4294967295) for channel 2. 'FALSE' - Number of pulses enter out of range (0 to 4294967295) for channel 2.
M00854	No_of_Total_Pulses_Setting_error_flag_CH3	'TRUE' - Number of pulses enter out of range (0 to 4294967295) for channel 3. 'FALSE' - Number of pulses enter out of range (0 to 4294967295) for channel 3.
M00862	No_of_Total_Pulses_Setting_error_flag_CH4	'TRUE' - Number of pulses enter out of range (0 to 4294967295) for channel 4. 'FALSE' - Number of pulses enter out of range (0 to 4294967295) for channel 4.
M00823	End_of_Total_Pulses_Flag_CH1	'TRUE' - pulses out completed for channel 1. 'FALSE' - pulse out not completed for channel 1.
M00839	End_of_Total_Pulses_Flag_CH2	'TRUE' - pulses out completed for channel 2. 'FALSE' - pulse out not completed for channel 2.
M00855	End_of_Total_Pulses_Flag_CH3	'TRUE' - pulses out completed for channel 3 'FALSE' - pulse out not completed for channel 3
M00863	End_of_Total_Pulses_Flag_CH4	'TRUE' - pulses out completed for channel 4. 'FALSE' - pulse out not completed for channel 4.
M00820	Acceleration_Time_Setting_error_flag_CH1	'TRUE' - Entered Acceleration Time is out of range for channel 1. 'FALSE' - Entered Acceleration Time is within range for channel 1 .
M00836	Acceleration_Time_Setting_error_flag_CH2	'TRUE' - Entered Acceleration Time is out of range for channel 2. 'FALSE' - Entered Acceleration Time is within range for channel 2 .
M00852	Acceleration_Time_Setting_error_flag_CH3	'TRUE' - Entered Acceleration Time is out of range for channel 3. 'FALSE' - Entered Acceleration Time is within range for channel 3 .

M00860	Acceleration_Time_Setting_error_flag_CH4	'TRUE' - Entered Acceleration Time is out of range for channel 4. 'FALSE' - Entered Acceleration Time is within range for channel 4.
M00821	Deceleration_Time_Setting_error_flag_CH1	'TRUE' - Entered Deceleration Time is out of range for channel 1. 'FALSE' - Entered Deceleration Time is within range for channel 1.
M00837	Deceleration_Time_Setting_error_flag_CH2	'TRUE' - Entered Deceleration Time is out of range for channel 2. 'FALSE' - Entered Deceleration Time is within range for channel 2.
M00853	Deceleration_Time_Setting_error_flag_CH3	'TRUE' - Entered Deceleration Time is out of range for channel 3. 'FALSE' - Entered Deceleration Time is within range for channel 3.
M00861	Deceleration_Time_Setting_error_flag_CH4	'TRUE' - Entered Deceleration Time is out of range for channel 4. 'FALSE' - Entered Deceleration Time is within range for channel 4.
M00108	Decel_Condition_CH1	'TRUE'- after instruction deactivate, Pulse output is stopped with decel for channel 1. 'FALSE'- after instruction deactivate, Pulse output is stopped immediately for channel 1.
M00109	Decel_Condition_CH2	'TRUE'- after instruction deactivate, Pulse output is stopped with decel for channel 2. 'FALSE'- after instruction deactivate, Pulse output is stopped immediately for channel 2.
M00110	Decel_Condition_CH3	'TRUE'- after instruction deactivate, Pulse output is stopped with decel for channel 3. 'FALSE'- after instruction deactivate, Pulse output is stopped immediately for channel 3.
M00111	Decel_Condition_CH4	'TRUE'- after instruction deactivate, Pulse output is stopped with decel for channel 4 'FALSE'- after instruction deactivate, Pulse output is stopped immediately for channel 4
MW0068	Elapsed_Value_CH1	This tag shows current pulses out at channel 1. (Y0 : Pulses, Y1 : Direction)
MW0084	Elapsed_Value_CH2	This tag shows current pulses out at channel 2. (Y2 : Pulses, Y3 : Direction)
MW1709	Elapsed_Value_CH3	This tag shows current pulses out at channel 3. (Y4 : Pulses, Y5 : Direction)
MW1791	Elapsed_Value_CH4	This tag shows current pulses out at channel 4. (Y6 : Pulses, Y7 : Direction)
MW0054	Trapezoidal_Min_Pulse_Count_Register_CH1	Count shows in this tag is the minimum pulses required to generate trapezoidal profile according to other input parameters for channel 1.
MW0056	Trapezoidal_Min_Pulse_Count_Register_CH2	Count shows in this tag is the minimum pulses required to generate trapezoidal profile according to other input parameters for channel 2.

MW1711	Trapezoidal_Min_Pulse_Count_Register_CH3	Count shows in this tag is the minimum pulses required to generate trapezoidal profile according to other input parameters for channel 3.
MW1793	Trapezoidal_Min_Pulse_Count_Register_CH3	Count shows in this tag is the minimum pulses required to generate trapezoidal profile according to other input parameters for channel 4.
M00140	Decel_Condition_Completed_CH1	When Decel_Condition_CH1 is TRUE and if instruction completed with deceleration then this flag is set.
M00141	Decel_Condition_Completed_CH2	When Decel_Condition_CH2 is TRUE and if instruction completed with deceleration then this flag is set.
M00142	Decel_Condition_Completed_CH3	When Decel_Condition_CH3 is TRUE and if instruction completed with deceleration then this flag is set.
M00143	Decel_Condition_Completed_CH4	When Decel_Condition_CH4 is TRUE and if instruction completed with deceleration then this flag is set.

6. Relative Position Control

Function

The instruction only supports the pulse output type: Pulse + Direction.

No of (Relative Positioning). The operation of Dir corresponds to the "+" or "-" of Number of Pulses. When Sign is "+", Dir will be OFF; when Sign is "-", Dir will be ON. Dir will not be OFF immediately after pulse output completion and will be OFF when the contact is OFF.

The Set value in the No of Pulses is Relative Position of the Current Position which is stored in Elapsed Value Register.

Executive Condition

Condition	Action
The rung-condition-in is false	The rung-condition-out is false
The rung-condition-in is true	The rung-condition-out is set to true only if Enable is true

Operands

Operands	Type	Descriptions
Enable	BOOL	BOOL Value Enable or Disable instruction.
Channel_No	USINT	Enter Channel number e.g. Enter '1' for CH-1(Y0-Pulses, Y1-Dir).
Start_End_Freq	UDINT	Start_End_Freq of Pulse Output i.e. Min Freq.

		If Entered freq is more/less than Specified freq then Freq_Setting_Error_Flag will be Set and Instruction will work at lower/upper bound of freq as Start_End_Freq.
Pulse_Op_Freq	UDINT	Pulse Output Frequency i.e. Max Freq. If Entered freq is more/less than Specified freq then Target_Frequency_Setting_Error_Flag will be Set and Instruction will work at lower/upper bound of freq as Pulse_Op_Freq.
Acc_Time_mS	UINT	Acceleration Time in mSec. If Entered time is more/less than specified range, then Acceleration_Time_Setting_error_flag will be set and instruction will work at lower/upper bound of Acceleration Time. For FL004-Series : unit is 1mSec :: FL005 & FL055 Series : unit is 10mSec.
Dec_Time_mS	UINT	Deceleration Time in mSec. If Entered time is more/less than specified range, then Deceleration_Time_Setting_error_flag will be set and instruction will work at lower/upper bound of Deceleration Time. For FL004-Series : unit is 1mSec :: FL005 & FL055 Series : unit is 10mSec.
NoOfPulses	DINT	Number of Pulses.
CH_Error	BOOL	If Entered Channel_No is more/less than the Pulse_Ramp channels that product have , then CH_Error is Set

Example

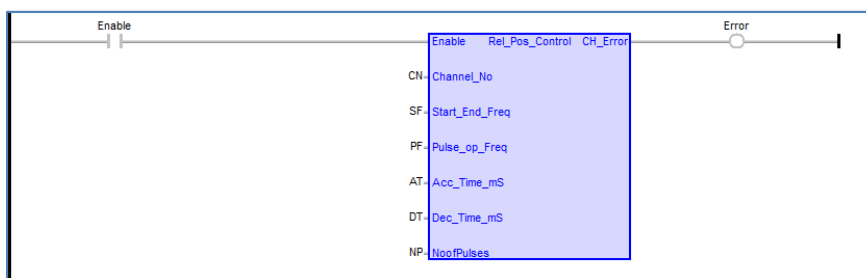

If CN = 1, Enable is ON & Configured Specified Input Parameters then Pulses will be out with Trapezoidal Profile on Selected Channels.

Channel_Num, Start_End_Freq, Pulse_Op_Freq, Acc_Time_mS, Dec_Time_mS & NoOfPulses are Entered then trapezoidal Profile will generate.

Trapezoidal_Min_Pulse_Count_Register_CHx shows the minimum pulses required to generate trapezoidal profile.

Trapezoidal_Min_Pulse_Count is calculated by using Start_End_Freq, Pulse_Op_Freq, Acc_Time_mS, Dec_Time_mS by PLC internally and shows count in Trapezoidal_Min_Pulse_Count_Register_CHx tag.

when NoOfPulses is +ve then pulse output executes forward operation, i.e. Dir = OFF;

when NoOfPulses is -ve then pulse output executes reverse operation, i.e. Dir = ON.

Associated Special Tags/Bits

Tags/Bits	Tag/Bit Name	Description
M00104	PulseOp_Dir_CoOrdinate_Change_CH1	When this bit is Set, Reverse the direction conditions of direction output Y1. if 'FALSE': NoOfPulses is +ve, Y1-OFF & NoOfPulses is - Baud_Rate_Com1ve, Y1-ON. if 'TRUE' : NoOfPulses is +ve, Y1-ON & NoOfPulses is -ve , Y1-OFF.
M00105	PulseOp_Dir_CoOrdinate_Change_CH2	When this bit is Set, Reverse the direction conditions of direction output Y3. if 'FALSE': NoOfPulses is +ve, Y3-OFF & NoOfPulses is -ve, Y3-ON if 'TRUE' : NoOfPulses is +ve, Y3-ON & NoOfPulses is -ve , Y3-OFF.
M00106	PulseOp_Dir_CoOrdinate_Change_CH3	When this bit is Set, Reverse the direction conditions of direction output Y5. if 'FALSE': NoOfPulses is +ve, Y5-OFF & NoOfPulses is -ve, Y5-ON. if 'TRUE' : NoOfPulses is +ve, Y5-ON & NoOfPulses is -ve , Y5-OFF.
M00107	PulseOp_Dir_CoOrdinate_Change_CH4	When this bit is Set, Reverse the direction conditions of direction output Y7. if 'FALSE': NoOfPulses is +ve, Y7-OFF & NoOfPulses is -ve, Y7-ON. if 'TRUE' : NoOfPulses is +ve, Y7-ON & NoOfPulses is -ve , Y7-OFF.
M00112	Pulse_Output_Pause_CH1	If This Bit is 'TRUE' - Stop Pulses immediately of channel 1 - Y0. 'FALSE' - Resume and starts Pulse out at Y0.
M00113	Pulse_Output_Pause_CH2	If This Bit is 'TRUE' - Stop Pulses immediately of channel 2 - Y2. 'FALSE' - Resume and starts Pulse out at Y2.
M00114	Pulse_Output_Pause_CH3	If This Bit is 'TRUE' - Stop Pulses immediately of channel 3 - Y4. 'FALSE' - Resume and starts Pulse out at Y4.
M00115	Pulse_Output_Pause_CH4	If This Bit is 'TRUE' - Stop Pulses immediately of channel 4 - Y6. 'FALSE' - Resume and starts Pulse out at Y6.
M00116	Pulse_Output_Pause_Status_CH1	Shows the status of 'Pulse_Output_Pause_CH1'.
M00117	Pulse_Output_Pause_Status_CH2	Shows the status of 'Pulse_Output_Pause_CH2'.
M00118	Pulse_Output_Pause_Status_CH3	Shows the status of 'Pulse_Output_Pause_CH3'.
M00119	Pulse_Output_Pause_Status_CH4	Shows the status of 'Pulse_Output_Pause_CH4'.

M00819	Frequency_Setting_error_flag_CH1	'TRUE' -Entered Start_end_freq frequency is out of range for channel 1. 'FALSE'- Entered Start_end_freq frequency is within range for channel 1.
M00835	Frequency_Setting_error_flag_CH2	'TRUE' -Entered Start_end_freq frequency is out of range for channel 2. 'FALSE'- Entered Start_end_freq frequency is within range for channel 2.
M00851	Frequency_Setting_error_flag_CH3	'TRUE' -Entered Start_end_freq frequency is out of range for channel 3. 'FALSE'- Entered Start_end_freq frequency is within range for channel 3.
M00120	Auto_Reset_After_Pulse_Completed_CH1	'TRUE' -Entered Start_end_freq frequency is out of range for channel 4. 'FALSE'- Entered Start_end_freq frequency is within range for channel 4.
M00121	Auto_Reset_After_Pulse_Completed_CH2	if this is 'TRUE' then after enter number of pulses out. Elapsed_Value_CH2 reset to zero and start pulse out again.
M00122	Auto_Reset_After_Pulse_Completed_CH3	if this is 'TRUE' then after enter number of pulses out. Elapsed_Value_CH3 reset to zero and start pulse out again.
M00123	Auto_Reset_After_Pulse_Completed_CH4	if this is 'TRUE' then after enter number of pulses out. Elapsed_Value_CH4 reset to zero and start pulse out again
M00124	Target_Frequency_Setting_Error_Flag_CH1	'TRUE' -Entered Pulse_op_Freq frequency is out of range for channel 1. 'FALSE'- Entered Pulse_op_Freq frequency is within range for channel 1.
M00125	Target_Frequency_Setting_Error_Flag_CH2	'TRUE' -Entered Pulse_op_Freq frequency is out of range for channel 2. 'FALSE'- Entered Pulse_op_Freq frequency is within range for channel 2.
M00126	Target_Frequency_Setting_Error_Flag_CH3	'TRUE' -Entered Pulse_op_Freq frequency is out of range for channel 3. 'FALSE'- Entered Pulse_op_Freq frequency is within range for channel 3.
M00127	Target_Frequency_Setting_Error_Flag_CH4	'TRUE' -Entered Pulse_op_Freq frequency is out of range for channel 4. 'FALSE'- Entered Pulse_op_Freq frequency is within range for channel 4.
M00822	No_of_Total_Pulses_Setting_error_flag_CH1	'TRUE' - Number of pulses enter out of range (0 to 4294967295) for channel 1. 'FALSE' - Number of pulses enter out of range (0 to 4294967295) for channel 1.
M00838	No_of_Total_Pulses_Setting_error_flag_CH2	'TRUE' - Number of pulses enter out of range (0 to 4294967295) for channel 2. 'FALSE' - Number of pulses enter out of range (0 to 4294967295) for channel 2.
M00854	No_of_Total_Pulses_Setting_error_flag_CH3	'TRUE' - Number of pulses enter out of range (0 to 4294967295) for channel.

		'FALSE' - Number of pulses enter out of range (0 to 4294967295) for channel 3.
M00862	No_of_Total_Pulses_Setting_error_flag_CH4	'TRUE' - Number of pulses enter out of range (0 to 4294967295) for channel 4. 'FALSE' - Number of pulses enter out of range (0 to 4294967295) for channel 4.
M00823	End_of_Total_Pulses_Flag_CH1	'TRUE' - pulses out completed for channel 1. 'FALSE' - pulse out not completed for channel 1.
M00839	End_of_Total_Pulses_Flag_CH2	'TRUE' - pulses out completed for channel 2. 'FALSE' - pulse out not completed for channel 2.
M00855	End_of_Total_Pulses_Flag_CH3	'TRUE' - pulses out completed for channel 3. 'FALSE' - pulse out not completed for channel 3.
M00863	End_of_Total_Pulses_Flag_CH4	'TRUE' - pulses out completed for channel 4. 'FALSE' - pulse out not completed for channel 4.
M00820	Acceleration_Time_Setting_error_flag_CH1	'TRUE' - Entered Acceleration Time is out of range for channel 1. 'FALSE' - Entered Acceleration Time is within range for channel 1.
M00836	Acceleration_Time_Setting_error_flag_CH2	'TRUE' - Entered Acceleration Time is out of range for channel 2. 'FALSE' - Entered Acceleration Time is within range for channel 2.
M00852	Acceleration_Time_Setting_error_flag_CH3	'TRUE' - Entered Acceleration Time is out of range for channel 3. 'FALSE' - Entered Acceleration Time is within range for channel 3.
M00860	Acceleration_Time_Setting_error_flag_CH4	'TRUE' - Entered Acceleration Time is out of range for channel 4. 'FALSE' - Entered Acceleration Time is within range for channel 4.
M00821	Deceleration_Time_Setting_error_flag_CH1	'TRUE' - Entered Deceleration Time is out of range for channel 1. 'FALSE' - Entered Deceleration Time is within range for channel 1.
M00837	Deceleration_Time_Setting_error_flag_CH2	'TRUE' - Entered Deceleration Time is out of range for channel 2. 'FALSE' - Entered Deceleration Time is within range for channel 2.
M00853	Deceleration_Time_Setting_error_flag_CH3	'TRUE' - Entered Deceleration Time is out of range for channel 3. 'FALSE' - Entered Deceleration Time is within range for channel 3.
M00861	Deceleration_Time_Setting_error_flag_CH4	'TRUE' - Entered Deceleration Time is out of range for channel 2.

		'FALSE' - Entered Deceleration Time is within range for channel 2.
M00108	Decel_Condition_CH1	'TRUE'- after instruction deactivate, Pulse output is stopped with decel for channel 1. 'FALSE'- after instruction deactivate, Pulse output is stopped immediately for channel 1.
M00109	Decel_Condition_CH2	'TRUE'- after instruction deactivate, Pulse output is stopped with decel for channel 2. 'FALSE'- after instruction deactivate, Pulse output is stopped immediately for channel 2.
M00110	Decel_Condition_CH3	'TRUE'- after instruction deactivate, Pulse output is stopped with decel for channel 3. 'FALSE'- after instruction deactivate, Pulse output is stopped immediately for channel 3.
M00111	Decel_Condition_CH4	'TRUE'- after instruction deactivate, Pulse output is stopped with decel for channel 4. 'FALSE'- after instruction deactivate, Pulse output is stopped immediately for channel 4.
MW0068	Elapsed_Value_CH1	This tag shows current pulses out at channel. 1. (Y0 : Pulses, Y1 : Direction)
MW0084	Elapsed_Value_CH2	This tag shows current pulses out at channel 2. (Y2 : Pulses, Y3 : Direction)
MW1709	Elapsed_Value_CH3	This tag shows current pulses out at channel 3. (Y4 : Pulses, Y5 : Direction)
MW1791	Elapsed_Value_CH4	This tag shows current pulses out at channel 4. (Y6 : Pulses, Y7 : Direction)
MW0054	Trapezoidal_Min_Pulse_Count_Register_CH1	Count shows in this tag is the minimum pulses required to generate trapezoidal profile according to other input parameters for channel 1.
MW0056	Trapezoidal_Min_Pulse_Count_Register_CH2	Count shows in this tag is the minimum pulses required to generate trapezoidal profile according to other input parameters for channel 2.
MW1711	Trapezoidal_Min_Pulse_Count_Register_CH3	Count shows in this tag is the minimum pulses required to generate trapezoidal profile according to other input parameters for channel 3.
MW1793	Trapezoidal_Min_Pulse_Count_Register_CH4	Count shows in this tag is the minimum pulses required to generate trapezoidal profile according to other input parameters for channel 4.
M00140	Decel_Condition_Completed_CH1	When Decel_Condition_CH1 is TRUE and if instruction completed with deceleration then this flag is set.
M00141	Decel_Condition_Completed_CH2	When Decel_Condition_CH2 is TRUE and if instruction completed with deceleration then this flag is set.

M00142	Decel_Condition_Completed_CH3	When Decel_Condition_CH3 is TRUE and if instruction completed with deceleration then this flag is set.
M00143	Decel_Condition_Completed_CH4	When Decel_Condition_CH4 is TRUE and if instruction completed with deceleration then this flag is set.

Revision History

Revision	Description	Date	Prepared by	Approved by
1.0	First Draft	19/07/2018	PM	AR
1.1	Revised Product Memory	04/04/2019	PM	AR
1.2	Added PWM Instruction	22/04/2019	PM	AR
1.3	Removed Native Ladder support	07/06/2019	PM	AR
1.4	Removed PWM configuration Tags	19/10/2019	PM	AR
1.5	Updated Total Memory	01/04/2020	PM	AR

The factory reserves the right to change or discontinue specifications and features without prior notice.

NOTES