

V200-19-RS4-X RS485/232 COM Port

V200-19-RS4-X is a communication module that enables you to install compatible Vision controllers with an additional COM port, COM 3. The port may be adapted to either the RS232 or the RS485 standard, via jumpers located on the module and with the appropriate VisiLogic program settings.

Note that V200-19-RS4-X is isolated.

Installation instructions begin on page 3.

For specific information on RS485/232 networking, refer to the controller's user guides and VisiLogic's Help file.

Component identification

1	J1 connector, plugs into PLC board
2	RJ11 connector
3	RS485/232 jumpers
4	Termination jumpers

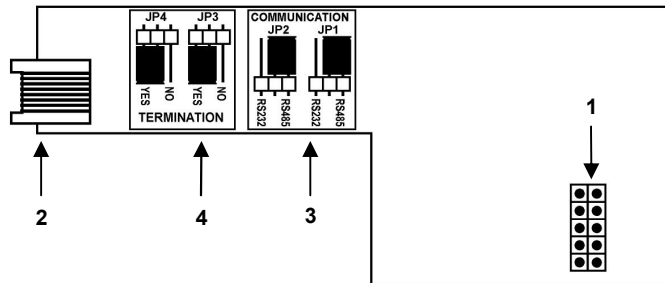

Module V200-19-RS4-X

User safety and equipment protection guidelines

This document is intended to aid trained and competent personnel in the installation of this equipment as defined by the European directives for machinery, low voltage and EMC. Only a technician or engineer trained in the local and national electrical standards should perform tasks associated with the electrical wiring of this device.

- Under no circumstances will Unitronics be liable or responsible for any consequential damage that may arise as a result of installation or use of this equipment, and is not responsible for problems resulting from improper or irresponsible use of this device.
- All examples and diagrams shown in the manual are intended to aid understanding. They do not guarantee operation.
- Unitronics accepts no responsibility for actual use of this product based on these examples.
- Only qualified service personnel should open this device or carry out repairs.
- Please dispose of this product in accordance with local and national standards and regulations.



- Turn off power before making communication connections.
- Check the user program before running it.
- Do not attempt to use this device with voltage exceeding permissible levels.
- Install an external circuit breaker and take appropriate safety measures against short-circuiting in external wiring.
- Do not connect the device directly to a telephone or telephone line.
- Ports must always be used with an appropriate adapter.



- Failure to comply with appropriate safety guidelines can result in severe personal injury or property damage. Always exercise proper caution when working with electrical equipment.



- Do not touch live wires.
- Double-check all the wiring before turning on the power supply.

RS232

RS232 Connector Pin-out

Pin Number	Function
1	DTR signal
2	0V reference
3	TxD signal
4	RxD signal
5	0V reference
6	DSR signal

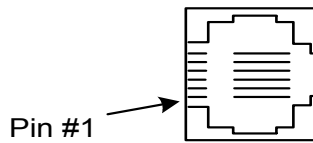

Note that standard programming cables do not provide connection points for pins 1 and 6. In addition, note that when a port is adapted to RS485, Pin 1 (DTR) is used for signal A, and Pin 6 (DSR) signal is used for signal B as shown in the RS485 pinout.

RS485 Wiring

Note that when a port is set to RS485, you can switch between end devices using either RS232 and RS485 without changing jumper settings. To enable you to do this, do not use flow control signals DTR and DSR.

- Caution*
- Use shielded, twisted pair cables.
 - Minimize the stub (drop) length leading from each device to the bus.
 - Ideally, the main cable should be run in and out of the network device.
 - Do not cross positive (A) and negative (B) signals. Positive terminals must be wired to positive, and negative terminals to negative.

RS485 Connector Pin-out

Pin Number	Function
1	A signal (+)
2	(RS232 signal)
3	(RS232 signal)
4	(RS232 signal)
5	(RS232 signal)
6	B signal (-)

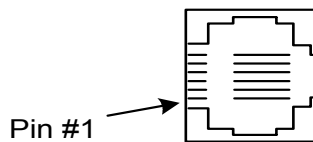

RS485 Network Termination Settings

The jumper settings shown below determine whether the controller can function as an end device in a RS485 network. Note that the factory default setting is ON. If the OPLC is not a network end device, set both jumpers to OFF.

RS232/RS485 Jumper Settings

The tables below show how to set a specific jumper to change the functionality of the port. To open the controller and access the jumpers, refer to the installation instructions below.

RS232/RS485 Jumper Settings

To use as:	JP2	JP1
RS232	RS232	RS232
RS485*	RS485	RS485

RS485 Termination Settings

Termination	JP4	JP3
ON*	Yes	Yes
OFF	No	No

* Default factory setting.

Installation Instructions

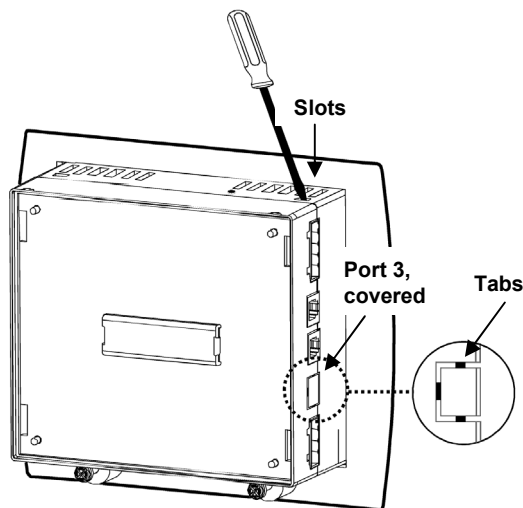

Figure 1. Opening the Controller

1. Turn power off before opening the controller.
2. If the controller has an installed Snap-in I/O module, remove it. Instructions are given in 'Removing a Snap-in Module' in the Vision User Guide.
3. Open the OPLC by inserting a screwdriver into the slots located on the sides of the controller as shown, then carefully prying the cover off.
4. The RS232/485 port's location, COM 3, is covered by plastic. Remove the plastic covering using a razor cutter to cut through the tabs shown in Figure 1.
5. Locate the J3 connector shown in Figure 2.
6. Install the module by placing the J1 connector (female) of the module onto the J3 connector (male) on the controller card as shown in Figure 3. Make sure that the connection is secure.
7. Close the controller by snapping the plastic cover back in its place. If the card is placed correctly, the cover will snap on easily.
8. If required, reinstall the Snap-in Module.

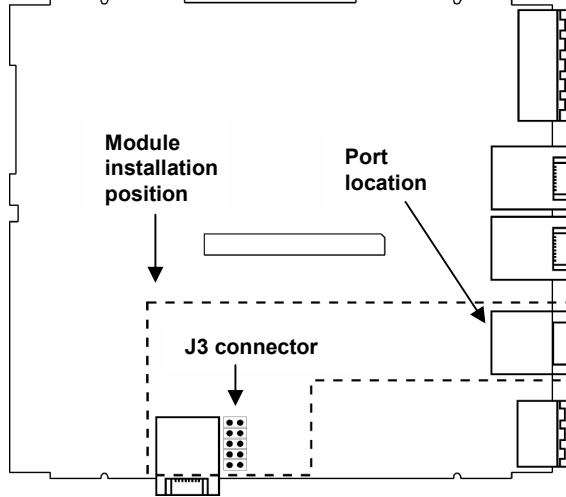

Figure 2. Controller, Main PCB Board

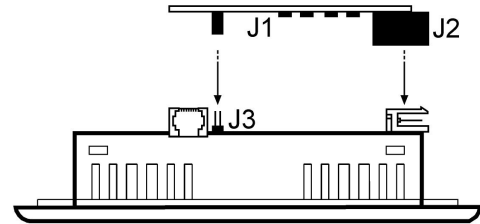

Figure 3. Installing the Module

Technical Specifications

Isolation	Yes
Weight	21g (0.74 oz)

Environmental

Operating temperature	0° to 50°C (32 to 122°F)
Storage temperature	-20° to 60°C (-4 to 140°F)
Relative Humidity (RH)	5% to 95% (non-condensing)

RS232 Port Specifications

Voltage limits	±20V
----------------	------

RS485 Port Specifications

Input Voltage	-7 to +12V differential max.
Cable type	Shielded twisted pair, in compliance with EIA RS485
Cable length	1200m maximum (4000 feet)
Baud rate	110 – 115,200 bps
Nodes	Up to 32

5408-0190-5