

PROFIBUS Compact Repeater

700-972-0RB12

Instruction Manual

Edition : 1.1 / 25.02.2008

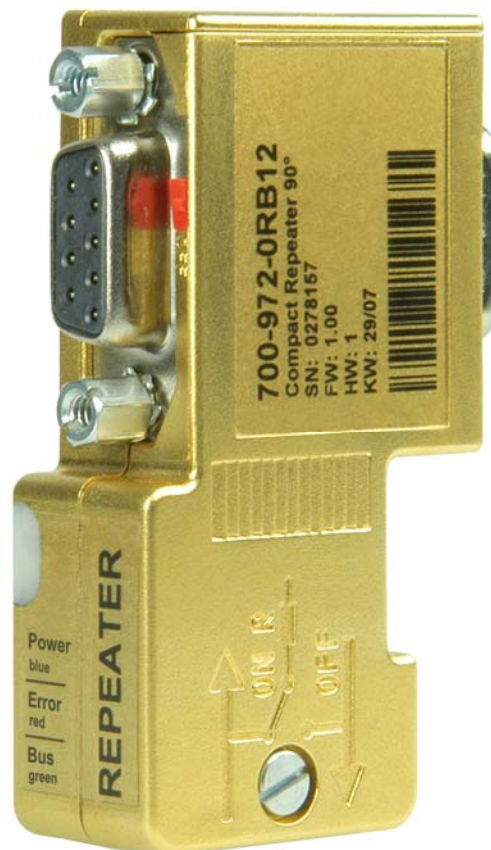

Order number of instruction manual: 900-972-0RB12/en

All rights are reserved, including those of translation, reprinting, and reproduction of this manual, or parts thereof. No part of this manual may be reproduced, processed, copied, or transmitted in any way whatsoever (photocopy, microfilm, or other method) without the express written permission of Systeme Helmholtz GmbH, not even for use as training material, or using electronic systems. All rights reserved in the case of a patent grant or registration of a utility model or design.

Copyright © 2007 by
Systeme Helmholtz GmbH
Gewerbegebiet Ost 36, 91085 Weisendorf, Germany

Note:

We have checked the content of this manual for conformity with the hardware and software described. Nevertheless, because deviations cannot be ruled out, we cannot accept any liability for complete conformity. The data in this manual have been checked regularly and any necessary corrections will be included in subsequent editions. We always welcome suggestions for improvement.

STEP and SIMATIC are registered trademarks of SIEMENS AG

Contents

1	Safety Information	4
1.1	General	4
1.2	Restriction of access	4
1.3	Target group for these instructions	5
1.4	Use as intended	5
1.5	Avoiding use not as intended!	5
1.6	Symbols used	5
2	Installation and Mounting	6
3	Short description of the PROFIBUS Compact Repeater	8
3.1	Application and function description	8
3.2	The LED display and its meaning	8
3.3	Connections	9
3.4	Examples of circuits	10
4	Technical Data	12
4.1	Operating conditions	12
4.2	Transmission rates	12
4.3	Accessories	13
5	Further documentation	13

1 Safety Information

The safety information indicates possible hazards and provides information about how you can avoid hazardous situations. Therefore please observe the safety information given for your own and other people's safety.

1.1 General

The **PROFIBUS Compact Repeater** is only used as part of a complete system.

 *The operator of a machine system is responsible for observing all safety and accident prevention regulations applicable to the application in question.*

 *During configuration, safety and accident prevention rules specific to the application must be observed.*

 *Emergency OFF facilities according to EN 60204 / IEC 204 must remain active in all modes of the machine system. The system must not enter an undefined restart.*

 *Faults occurring in the machine system that can cause damage to property or injury to persons must be prevented by additional external equipment. Such equipment must also ensure entry into a safe state in the event of a fault. Such equipment includes electromechanical safety buttons, mechanical interlocks, etc. (see EN 954-1, risk estimation).*

 *Never execute or initiate safety-related functions using the operator terminal.*

1.2 Restriction of access

The PROFIBUS Compact Repeater is an open item of equipment and must only be installed in electrical equipment rooms, cabinets or housings. Access to the electrical equipment rooms, barriers, or housings must only be possible using a tool or key and only permitted to personnel having received instruction or authorization. See also Chapter 2.



Only authorized persons must have access to the PROFIBUS Compact Repeaters!

1.3 Target group for these instructions

These instructions are addressed to project planners and installers of PROFIBUS Compact Repeater.

It is intended as a reference work for project planners. It provides the installing technician with all the necessary data.

The PROFIBUS Compact Repeater is intended for use in a PROFIBUS network only. For that reason, the configuring engineer, user, and installing technician must observe the standards, safety and accident prevention rules applicable in the particular application. The operator of the automation system is responsible for observing these rules.

1.4 Use as intended

The PROFIBUS Compact Repeater must only ever be used as described in these instructions.

1.5 Avoiding use not as intended!

Safety-related functions must not be controlled using the PROFIBUS Compact Repeater alone.

1.6 Symbols used

The following symbols are used in this manual.



Caution, indicates hazards and sources of error



Hazard, general or specific



Danger of electric shock



Gives information

2 Installation and Mounting

The PROFIBUS Compact Repeater must be installed according to VDE 0100 IEC 364. The PROFIBUS Compact Repeater has degree of protection IP20.

Ambient temperature: 0 °C – 60 °C.



Before you start installation work, all system components must be disconnected from their power source. Danger of electric shock!



During installation, the safety and accident prevention rules that apply to the specific application must be followed (e.g. protection against static discharges).

The PROFIBUS Compact Repeater is plugged directly into the SUB D female connector of the PROFIBUS station instead of the normal PROFIBUS device connector. It is locked in place with the two screws on the sides.

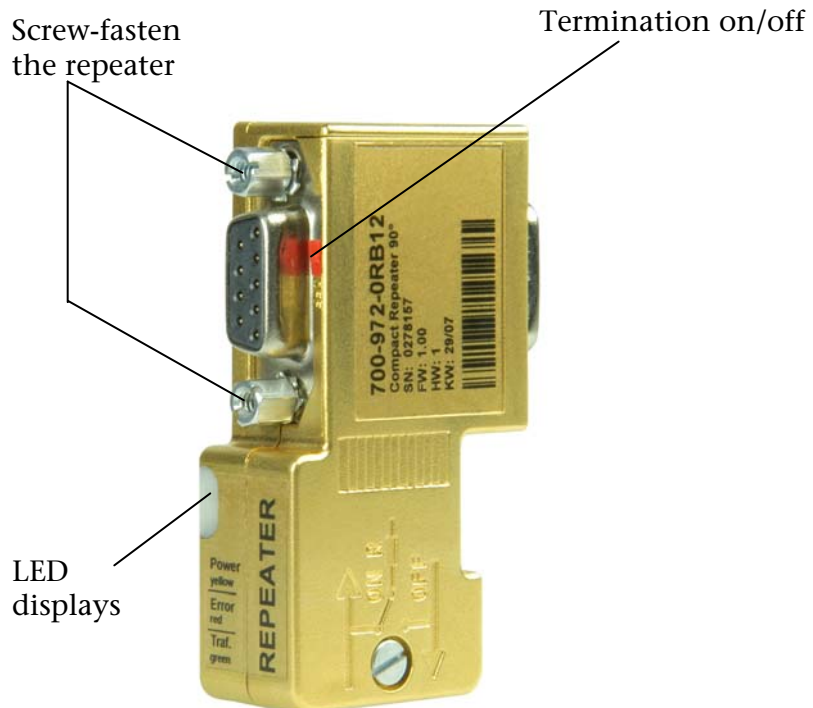

Via the SUB D female connector, a diagnostic device or a stub line can be connected. The front panel must be accessible in this case.

The cables of the PROFIBUS are routed downward out of the repeater housing. There must be room for the PROFIBUS cables here.

If the PROFIBUS Compact Repeater is at the end of a segment, the termination must be ON.

If the PROFIBUS Compact Repeater is in the middle of a segment (e.g. to start a stub line), you must switch the termination OFF.

3 Short Description of the PROFIBUS Compact Repeater

3.1 Application and function description

The PROFIBUS Compact Repeater is a normal PROFIBUS Compact Repeater despite its small dimensions. It regenerates the electrical signal arriving on the bus line and retransmits it. The level, edge steepness, and mark-to-space ratio of the signals are reproduced exactly. At the same time, it electrically isolates the receive lines from the transmit lines.

These functions can be used

- 1.) to add a further segment to an existing PROFIBUS (in series or as a stub line). This increases the possible number of stations on the PROFIBUS by another 31.
- 2.) to cover long cable distances without any reduction in data transmission rate. Up to three PROFIBUS Compact Repeaters can be connected in series.

The PROFIBUS Compact Repeater is looped into the PROFIBUS in place of a normal PROFIBUS connector. This permits the extension, segmentation or branching of the PROFIBUS without extensive installation. The device is plugged into the PROFIBUS Compact Repeater and supplies the PROFIBUS Compact Repeater with the necessary power (+5V). This is done via the SUB D connector.

The PROFIBUS Compact Repeater permits transmission rates of 9.6 Kbps to 12 Mbps.

3.2 The LED display and its meaning

The front of the housing of the PROFIBUS Compact Repeater contains a small white surface (see Fig. on Page 6). Behind this white surface, you will find three LEDs that show you the operating status of the PROFIBUS Compact Repeater and the connected PROFIBUS Segment 2.

Meanings:

Color	Flashing /continuous	Meaning
Blue	Flashing	Repeater is detecting the baudrate
	Continuous	Baudrate has been detected
Green	Flashing or continuous	Data exchange is in progress on Segment 2
Red	Flashing or continuous	Repeater finds one or more errors on Segment 2

3.3 Connections

The PROFIBUS is connected to the PROFIBUS Compact Repeater via a terminal block, see Fig. 3-1. To do this, the PROFIBUS Compact Repeater must be opened. The shielding is grounded via the metallized repeater casing.

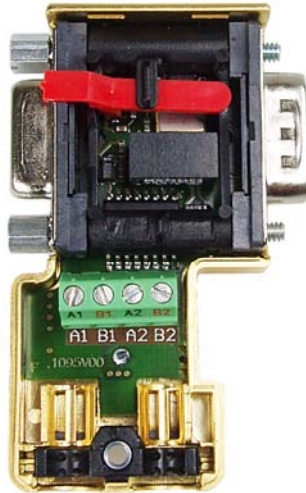

Fig. 3-1: PROFIBUS Compact Repeater, opened

Power supply	via Sub D connectors of the PROFIBUS station
Segment 1	A1 green cable B1 red cable
Segment 2	A2 green cable B2 red cable

SUB D female connector

An operator panel or programming unit can be connected to the Sub D female connector of the PROFIBUS Compact Repeater. The SUB D female connector can also be used for a PROFIBUS stub line. The SUB D female connector is connected to Segment 1.

Pin assignment

Pin	PROFIBUS / SUB D connector 9-way
1	-
2	M 24 V
3	DATA B
4	-
5	GND
6	+5V
7	+24 V
8	DATA A
9	-

3.4 Examples of circuits

The combinations that are possible to derive bus structures can be derived from the block diagram, see Fig. 3-2:

!
The bus cables are always connected as stub lines. Do not connect Ax/Bx and Ax'/Bx' by cable!

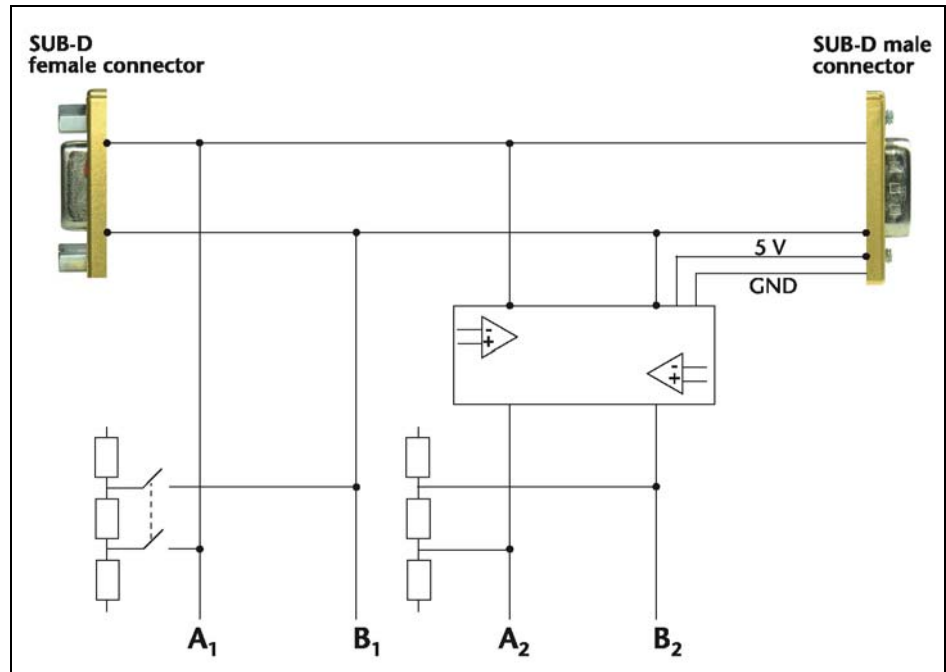

Fig. 3-2:
 Block diagram of the repeater

For long bus lines, repeaters can be connected in series (up to three repeaters):

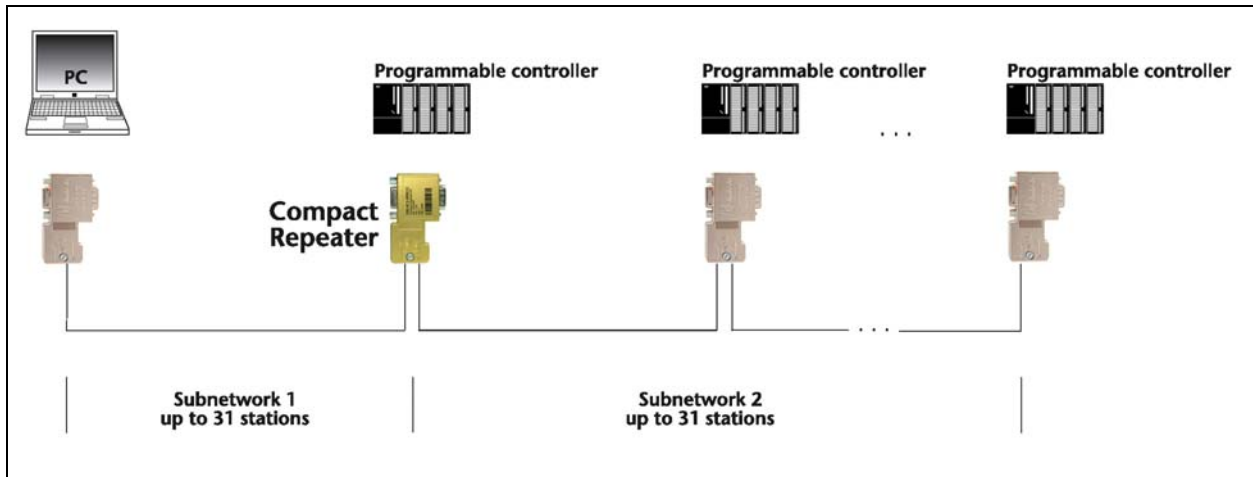

Fig. 3-3:
 Application example of a long bus line

For complex bus structures, the bus can be constructed with hierarchical or star topology using repeaters.

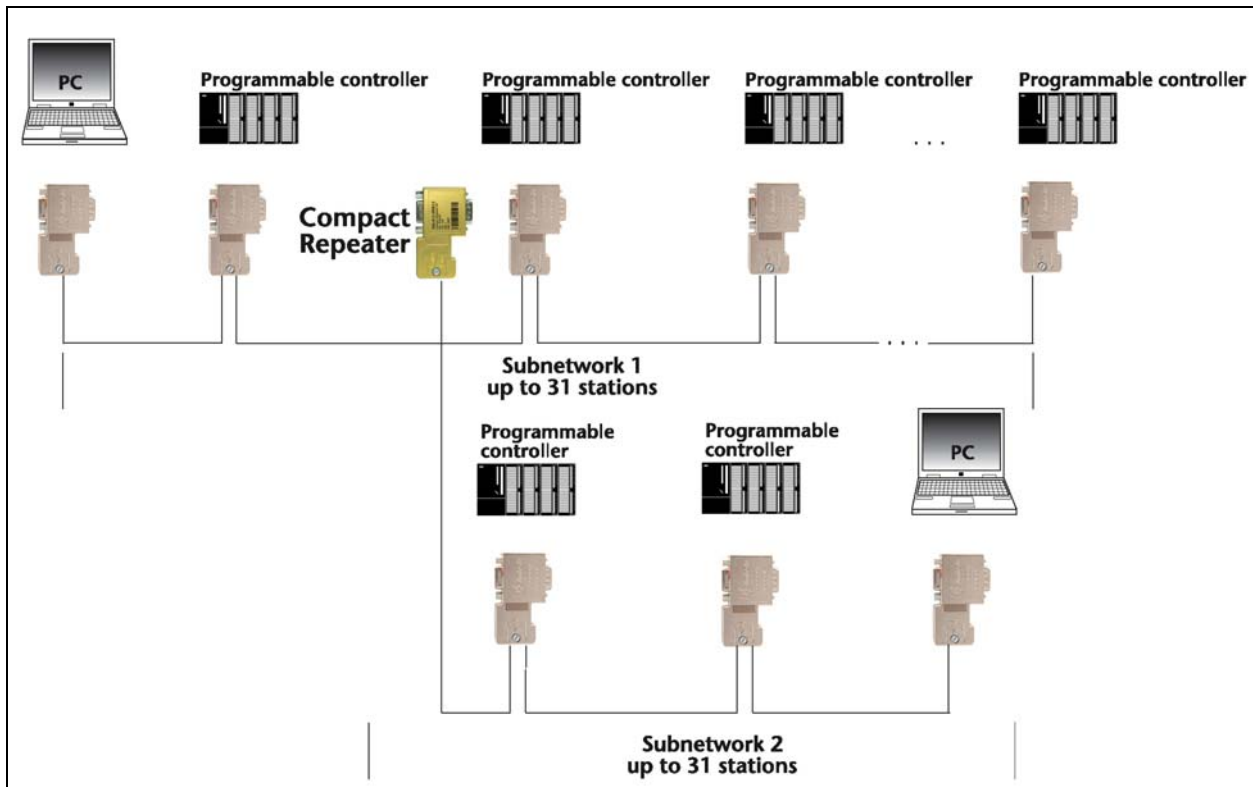

Fig. 3-4:
Application example of
more than 32 stations

Up to 31 stations can be connected to one repeater in a subnetwork. The number of stations can be increased still further by interposing further repeaters.

4 Technical Data

4.1 Operating conditions

Dimensions in mm (LxWxH)	64 x 40 x 17
Weight	approx. 40 g
Housing	IP 20
Power supply	
Voltage	+5 V DC
Current consumption	typically 100 mA
Permissible ambient conditions	
• Ambient temperature during operation	0 °C ... +60 °C
• Temperature during transportation and storage	-25 °C ... +75 °C
PROFIBUS interface	
Transmission rate	9.6 Kbps to 12 Mbps, automatic detection
Protocol PROFIBUS DP	per EN 50 170
Connector	SUB D 9-way
Special features	
Quality assurance per ISO 9001:2000	
Maintenance	Maintenance-free, no battery

4.2 Transmission rates

The transmission rates on the bus segment are automatically detected by the **PROFIBUS Compact Repeater**.

Transmission rate	Max. segment length
9.6 Kbps	1000 m
19.2 Kbps	1000 m
45.45Kbps	1000 m
93.75Kbps	1000 m
187.5Kbps	1000 m
500 Kbps	400 m
1.5 Mbps	200 m
3 Mbps	100 m
6 Mbps	100 m
12 Mbps	100 m

4.3 Accessories

Manual, German/English	900-972-0RB12/de 900-972-0RB12/en
EasyConnect [®] PROFIBUS connector without PG	700-972-0BA50
EasyConnect [®] PROFIBUS connection with PG	700-972-0BB50
EasyConnect [®] PROFIBUS connector for flexible cables, without PG	700-972-0FA50
EasyConnect [®] PROFIBUS connector for flexible cables, with PG	700-972-0FB50
Bus connector for PROFIBUS 90° without PG	700-972-0BA12
Bus connector for PROFIBUS 90° with PG	700-972-0BB12
Bus connector for PROFIBUS 35° without PG	700-972-0BA41
Bus connector for PROFIBUS 35° with PG	700-972-0BB41
Bus connector for PROFIBUS axial	700-972-0CA12
Bus connector for PROFIBUS with Atex approval, without PG, Ex-Zone 2	700-973-0BA12
Bus connector for PROFIBUS with Atex approval, with PG, Ex-Zone 2	700-973-0BB12
PROFIBUS connector diagnostics without PG	700-972-7BA12
PROFIBUS connector diagnostics with PG	700-972-7BB12
Insulation stripping tool for PROFIBUS	700-972-6AA00

5 Further Documentation

Internet: www.helmholz.de, www.profibus.de

Siemens Manuals: "Installing and Wiring the S7-300/S7-400", "S7-300 Module Data"

"Profibus DP/DPV1", Manfred Popp, Hüthig Verlag

"Profibus-Handbuch", Max Felser, Berner Fachhochschule, CH-3400 Burgdorf,

<http://www.profibus.felser.ch/planung/installation/PROFIBUSInstallation%20D11.pdf> (in German)

Notes